

A dynamic operationalization of Sen's capability approach

Marco Grasso^{*}

Abstract

The limits of the utilitarian approach have led to a search for different notions of welfare. The income approach to well-being, in fact, doesn't account for the diversity in human beings and for the heterogeneities of contingent circumstances. Amartya Sen, looking for broader notions of well-being, has developed an approach focused on the freedom of individuals to pursue their own project of life: the capability approach. The main purpose of the paper is to explore the possibility of using system dynamics to operationalize Sen's framework. First of all we address the methodological issues that have to be considered in order to operationalize the capability approach in a dynamic framework. Then we investigate the architecture of the three-functionings model we devised to represent human well-being, as intended in the capability approach. Furthermore, we analyze in depth the structure of a particular functioning, and consider some simulations for the selected functioning and for the whole model over time. Finally, the concluding remarks suggest some indications about the use of system dynamics in order to operationalize the capability approach, and consider the main findings derived from the simulations carried out.

JEL: I31

^{*} Dipartimento di Sociologia e Ricerca Sociale, Università degli Studi di Milano Bicocca. Email: marco.grasso@unimib.it

Introduction

The view that the traditional utilitarian notion of welfare can render only a partial picture of human well-being is nowadays quite widely accepted by the community of economists. In fact this conception relies only on the welfarist criteria of utility (in theory) and income (in application). The consequent measurements of welfare are generally derived through the observation of preferences revealed by actual choices, and interpreted in terms of the numerical representation of these choices¹. Therefore the notion of welfare reflects only the class of differences captured by money metric, under the economic rationality of self-interested utility maximization. Moreover, the income approach to well-being doesn't account for the diversity in human beings and for the heterogeneities of contingent circumstances². Thus income can be intended only as a mean to reach an acceptable standard of living, and in no way as an end in itself, since there are other important dimensions to the flourishing of human well-being that income doesn't account for: health, education, social relationships, longevity, employment, environmental conditions, housing conditions.

The need to move towards such a broader notion of well-being has been strongly advocated, among others, by Amartya Sen, whose major contributions all stress the centrality of individual entitlements, opportunities, and rights as conceptual foundations of economics and social choice. Sen has in fact gradually developed an approach³ focused on the freedom of individuals to pursue their own project of life, in which well-being is seen «in terms of a person's ability to do valuable acts or reach valuable states of being» (Sen, 1993:30). This is the core of the so-called capability approach.

The multidimensionality of the capability approach doesn't simply lie in the broadening of the evaluative spaces. In fact this approach also redefines the concept of well-being itself, stressing the importance of a systemic view, dependent «on a number of contingent circumstances, both personal and social» (Sen, 1999:70). Given the rich array of issues and of levels, the operationalization of the capability approach is not straightforward. Anyway, Sen himself, though acknowledging the empirical difficulties, ascribes significant importance to the practical usability of the framework he has depicted: «the approach must nevertheless be practical in the sense of being usable for actual assessment of the living standard» (Sen, 1987(b):20). For this reason he has provided a possible formalization (Sen, 1985), that turns the capability approach into a fully fledged economic theory, besides being a field of interest to philosophers and scholars of development studies.

The main purpose of this paper is to explore the possibility of using system dynamics to operationalize Sen's approach. The paper is structured as follows. Section 1 addresses the methodological issues that have to be considered in order to operationalize the capability approach in a dynamic framework. Section 2 investigates the architecture of the three-functionings model we devised to represent human well-being as intended by Sen in the capability approach. Section 3 analyzes in depth the structure of a particular functioning of the model, Physical and Psychological Health (the remaining two functionings – Education and Training, and Social Interactions – are briefly considered in annex I and II). Section 4 considers some simulations of the selected functioning, and of the whole model over time (similar simulations are carried out for the remaining two functionings in annex III and IV). Finally, the concluding remarks briefly consider the main findings derived from the simulations carried out.

¹ In the traditional utilitarian framework (from Bentham, to Edgeworth, Marshall, Pigou), the concept of utility is simply a matter of pleasure, happiness, desire fulfillment. The main limit of this view is that utility is seen in terms of mental metric, highly subjective and therefore possibly misleading.

² A complete critique of the pitfalls of utilitarian approach is beyond the goals of this paper.

³ See, for instance, Sen (1980, 1985, 1987(b), 1992, 1999).

1 Operationalizing Sen's approach: methodological issues

By operationalization we mean all the steps between a theory and its empirical application. Such an application relies on the translation of theoretical concepts into quantifiable variables: in brief, in Sen's framework the resources or commodities must be turned into functionings and capabilities. Henceforth we consider the capability approach primarily as a method for making interpersonal comparison of well-being. Indeed in Sen's intention it has a far wider significance: it is first of all a framework of thought, which aims at highlighting the drawbacks of other approaches in identifying and defining welfare. Since Sen's interest seems to be mainly concerned with this foundational level, he has never provided a formula or "path" to carry out welfare measurements and comparisons⁴. Actually, incompleteness is not surprisingly a distinctive characteristic of the capability approach, for it depends on the context of the evaluation, which is as ambiguous and complex as human life and values are.

Sen's approach requires «a broader informational base, focusing particularly on people's capability to choose the life they have reason to value» (Sen,1999:63), to highlight the social and economic factors which give people the opportunity to do and to be what they consider valuable for their fulfillment. Thus the capability approach focuses directly on the substantive freedoms of the individuals involved. In this sense, Sen suggests that well-being (or the standard of living⁵) be considered in terms of human functionings and capabilities. Functionings relate to what a person may value doing or being: they are the living conditions achieved by an individual and represent a set of interrelated activities and states ("doings" and "beings") that form her life. Capabilities concern the ability of an individual to achieve different combinations of functionings, and define the freedom to choose the life that she prefers. These two categories are complementary but however distinct: «A functioning is an achievement, whereas a capability is the ability to achieve. Functionings are, in a sense, more directly related to living conditions, since they are different aspects of living conditions. Capabilities, in contrast, are notions of freedom, in the positive sense: what real opportunities you have regarding the life you may lead» (Sen, 1987:36).

The notion of well-being in the capability framework involves a vast set of functionings and capabilities to disclose every aspect of life. If the main aim is to assess the overall standard of living, we nonetheless need to specify a reasonable and manageable subset of functionings and capabilities. Sen has never provided any list or guideline for the definition of this subset, stressing on the contrary that it varies through time and across space according to the intrinsic characteristics of the people concerned, the prevailing social costumes and cultural norms, and to economic factors. However the operationalization of the capability approach is basically a matter of pragmatism: «The foundational affirmation of the importance of capabilities can go with various strategy of actual evaluation involving practical compromises. The pragmatic nature of practical reason demands this» (Sen, 1999:85). Therefore the sense of the operationalization is contingent on the nature of the exercise, data constraints and the goals of the analyst. Hence the capability approach can be used in different ways depending on the context; it cannot be rigidly formulated because it is intentionally an open and flexible framework.

All the theoretical issues concerning this approach have been satisfactorily investigated in Sen's work and in the related literature, and it is not the aim of this paper to reconsider them.

⁴ With great disappointment of those who have looked into Sen's writings for such a "recipe".

⁵ The standard of living in Sen's view has a narrower connotation than well-being, the former relating only to the individual, while the latter includes also "sympathy" for other individuals. Sen also introduced the even wider notion of agency, which broadens the notion of well-being by taking into account social commitment. So, basically, we use the term "well-being" instead of the more appropriate "standard or living" to keep on with the traditional vocabulary of the literature on the argument.

Rather, we intend to highlight the methodological issues that must be considered in order to operationalize the capability approach in a dynamic framework.

In short, these are:

- the meaning and the space of operationalization;
- the *locus* of operationalization;
- the role of indicators;
- the importance of personal and social conversion factors;
- the selection and the aggregation of functionings.

1.1 The meaning and the space of operationalization

In general, Sen’s approach requires the translation of goods and services (i.e. commodities) into valuable beings and doings (i.e. functionings), from which the various combinations of achievable functionings (i.e. capabilities) may be chosen. In other words, commodities, sifted by personal and social conversion factors, allow the achievement of a number of beings and doings, which may be represented by the vectors of functionings (or the capability set). The choice of a specific subset (a vector) of functionings generates a given level of well-being.

Figure 1 - The capability approach: a general view

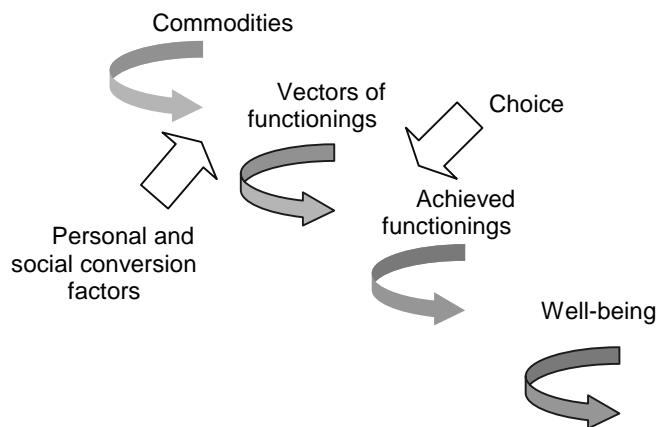

In order to render a dynamic simulation of the capability approach we must introduce a major simplification⁶: we restrict the model to the space of the chosen vector of functionings. Doing so we avoid the issue of the measurement of capabilities, and bypass the problem of their unobservability⁷. As Brandolini and D’Alessio point out (1998:12): «...embodying freedom into the notion of well-being is very demanding from an informational viewpoint, since the attempt to measure capabilities implies the hypothetical situations which never occurred and might never occur must be taken into account». Therefore we too stick to Basu’s suggestion – reported in Brandolini and D’Alessio (1998:15)–: «...to go along with Sen and evaluate well-being on the basis of functionings, but be content with achievements, instead of capabilities». Sen himself suggests that at a practical level the most appropriate focus of attention shouldn’t always lie in

⁶ We are aware of other areas of incompleteness with respect to the foundational theory, for instance:

- we ignore the distinction between “commodities” and “commodities characteristics”, because we consider this transformation to be part of the role of conversion factors;
- we do not distinguish between fundamental capabilities and basic capabilities;
- we do not introduce the category of refined functionings.

⁷ In fact their potential nature can become actual only after an individual’s process of choice.

the measure of capabilities: «Some capabilities are harder to measure than others and attempts to putting them on a “metric” may sometimes hide more than they reveal» (Sen, 1999: 81). Furthermore, the chosen vector of functionings could be seen as an elementary valuation of the capability set, which depending on the appropriate choice of elements of the vector (i.e. assuming a maximizing behavior), can in turn be considered as the maximally valued element⁸.

In our simplified model, well-being is a function of the achieved functionings; the functionings are converted commodities, where the conversion factors arise from personal and social characteristics. More specifically, in the three-functionings example of Figure 2 a number of commodities (1,...n) determine each achieved functioning (A, B, C), via the conversion factors which take account of personal and social diversities.

We think that this schematic representation is quite consistent with Sen’s view of well-being operationalization: «We use incomes and commodities as the material basis of our well-being. But what use we can respectively make of a given bundle of commodities, or more generally of a given level of income, depends crucially on a number of contingent circumstances, both personal and social» (Sen, 1999: 70). These different contingent circumstances «make opulencea limited guide to welfare and the quality of life» (Sen, 1999: 71).

Since we stress the importance of personal and social characteristics as the ultimate divide between a multidimensional assessment of well-being and the one based on Sen’s capability approach, we call our tentative operationalization of the latter the “Conversion Factors Model” (CFM).

Figure 2 – The capability approach: a schematic operationalization via the “Conversion Factors Model”

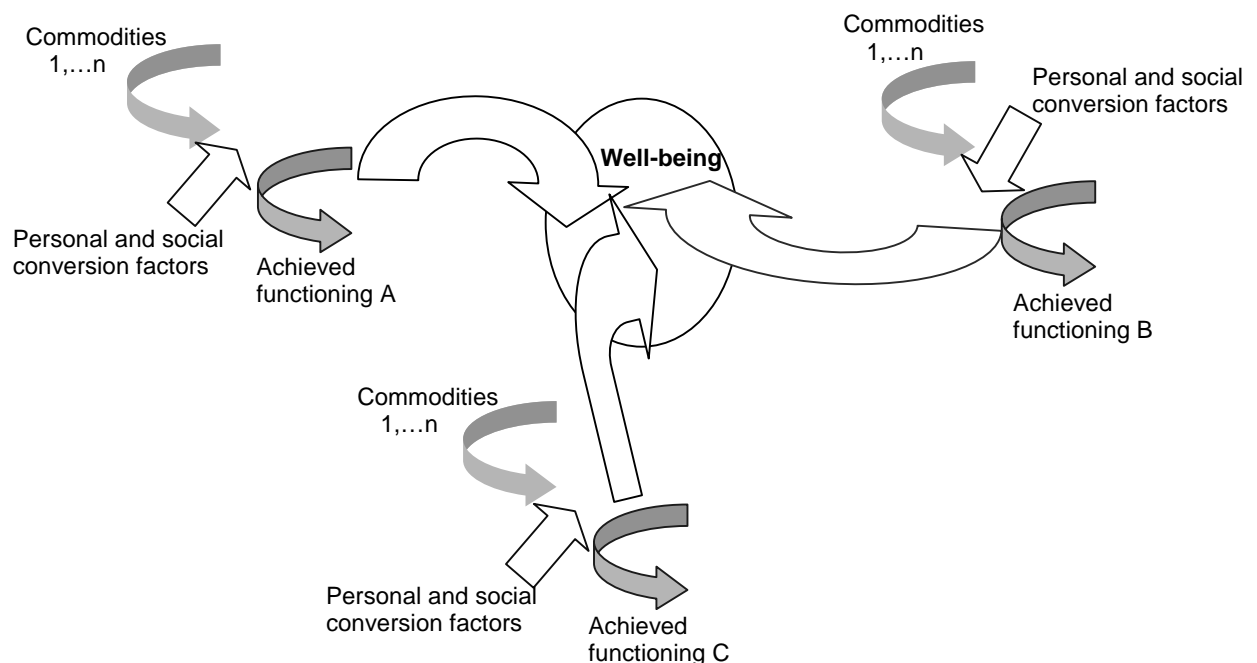

⁸ In this meaning the value of the capability set is that of a single element of the set, the maximally valued one. But this view holds if freedom is considered only in its instrumental meaning, and not in its substantive, positive meaning. In this latter case we inevitably should have pushed our analysis to the capability set, with all the problems deriving from unobservability and from increase of information required.

1.2 The *locus* of operationalization

From a theoretical point of view the reference unit of the capability approach is the individual, functionings and capabilities being in fact properties of individuals. More specifically, Sen moves in the space of ethical individualism and considers the individual as the only unit that counts when evaluating social states. At the same time, he avoids reducing society to the mere sum of individuals and their properties, as set by ontological individualism. Actually, the conversion factors (i.e. personal and social characteristics) can help or hinder the translation of commodities into functionings.

Notwithstanding, Sen himself in applying the capability approach refers to regional, national, sub-national, or group data. For instance, when examining poverty and deprivation in India and Sub-Saharan Africa (Sen, 1999:99-104), he draws on national and sub-national level data. Or, when dealing with gender inequality, he works both with different territorial level data and group data (Sen, 1999: 104-107).

The use of different units of analysis (groups based on age, gender, administrative boundaries or other elements) in the empirical work points out intergroup variations, but according to Sen (1992: 117, n.1) the focal point of the analysis remains the individual, since the interest in group is only derivative (i.e. regarding the differences among individuals placed in different groups) and not intrinsic (i.e. regarding the differences between groups seen as unique bodies). The rationale for this shifting to an aggregate reference unit can be usefully found in Dasgupta (1999:11): «Aggregate well-being for a given cohort of people will then be regarded to be the average well-being of the cohort. The thought-experiment I invoke to do this is the now-familiar conception due to Harsanyi (1955), in which the standard of living in a society is deduced to be the expected living standard of someone who had equi-probability of finding themselves in the place of each member of society».

In CFM the relevant unit of analysis is at sub-national level⁹ (we apply CFM to Italian administrative regions), both for practical reasons and for comparison purposes (between Italian regions). In spite of this assumption, we remain aware that a distinction, at least, of different social groups would be very important: the real achievement of a functioning, besides depending on commodities, results also from the individual characteristics of the beneficiaries. The “generalist” conversion factors that we use can in fact render the translation of commodities into functionings only at an aggregate level. If we had the possibility of identifying different social groups based on some important individual characteristic such as age, we would have depicted a more comprehensive model, in which the other conversion factors (environmental, social and relational - see Sen, 1999: 70-71) would have played a more “targeted” translation role. Anyway, losing the keener in-depth perspective of individual analysis is the price we have to pay to obtain a policy tool, which hopefully will be useful for simulations of well-being dynamics over time.

1.3 The role of indicators

We intend by indicators «statistic of direct normative interest which facilitates concise, comprehensive and balanced judgements about the condition of major aspects of a society. It is in all cases a direct measure of welfare and is subject to the interpretation that if it changes in the “right” direction, while other things remain equal, things have gotten better, or people are “better off”» (Olson, 1969:97). In CFM we use indicators both as proxy of commodities and of conversion factors.

⁹ This is also the level of practical measures such as *per capita* GDP and UNDP’s Human Development Index.

Indicators as proxy of commodities

In CFM indicators must represent the commodities necessary to achieve functionings. The selected indicators ought to be determinants of well-being, i.e. they must represent «goods and services which are inputs in the production of well-being» (Dasgupta, 1999:11), since their purpose is to measure the means by which social outcomes are achieved, and not social outcomes themselves. In fact, relying on the outputs of well-being (i.e. choosing constituent indicators), would provide “performance” measures, while, in a sense, we should measure social performances in the space of achieved functionings, not in the one of commodities (indicators). Furthermore, in our simplified dynamic context the commodity indicators are the locus of change: their (positive or negative) growth rate is in fact the only lever that can move the system toward new equilibriums over time.

Indicators as proxy of conversion factors

These indicators aren't directly related to well-being, they just convert (translate) commodities into functionings. They are sources of variation between the commodities basis and «the advantages – the well-being and freedom – we get out of them» (Sen, 1999:70). According to Sen's paradigm (1999:70, 71) these indicators could be framed in families of diversities: i) personal heterogeneities, ii) environmental diversities, iii) variations in social climate¹⁰:

- I. personal heterogeneities imply that people with different physical characteristics have different needs and thus require different level of income/resources to obtain the same level of well-being: «For example an ill person may need more income to fight her illness – income that a person without such an illness would not need;» (Sen, 1999:70);
- II. different environmental conditions (pollution, environmental hazards, climatic circumstances) affect the quality of life of dwellers of a given region;
- III. «The conversion of personal incomes and resources into the quality of life is influenced also by social conditions, including public educational arrangements, and the prevalence or absence of crime and violence in the particular location» (Sen, 1999:70-71).

1.4 The importance of personal and social conversion factors

Personal and social conversion factors play a pivotal role in Sen's capability approach: «One of the major strengths of the capability approach is that it can account for interpersonal variations in conversion of the characteristics of the commodities into functionings» (Robeyns, 2000: 6). For this unique “conversion power” they are the cornerstone of CFM. Personal and social conversion factors are in fact the catalysts that determine the degree of conversion of resources into capabilities (or in Sen's vocabulary, of commodities into functionings). Their converting role entails that individuals cannot be considered only in terms of the resources they have. They have to be weighed also in terms of their ability and opportunity to convert these resources into valuable beings and doings: «Even if it is accepted (as Rawls, 1971, has argued) that everyone may need the very same resources of primary goods to pursue their diverse ends (no matter what this ends are) there still remains the “conversion problem”, to wit, interpersonal variations in the functional relation between *resources* and *achievements*.» (Sen, 1994:335).

The essentiality of the conversion issue lies in the fact that it allows the capability approach to account explicitly for diversity: in fact if we assume that everybody can convert income and/or commodities into functionings and capabilities at the same rate, there would be no point

¹⁰ Sen points out other two sources of diversity: the differences in relational perspectives, and the distribution within the family. In CFM we do not consider the former since it does not have great explicative power in a developed society like the Italian one, in which conventions and customs are quite homogeneous. Nor do we consider the latter, since CFM works at a more aggregate level.

in defining well-being «in terms of a person's ability to do valuable acts or reach valuable states of being» (Sen, 1993:30), since there would be no difference between the latter and the commodities basis. If, on the contrary, we introduce personal and social conversion factors, well-being will differ substantially from the undifferentiated notion of welfare based on income and/or commodities: «Indeed if human beings would not be diverse, then inequality in one space, say income, would be more or less the same in another space, like functionings or capabilities» (Robeyns, 2000:6).

1.5 The selection and the aggregation of functionings

The selection of functionings and their aggregation are fundamental but troublesome issues in any attempt to operationalize the capability approach. In general, the broader the evaluative space, the closer we get to the inclusion of all possible elements of well-being; but, at the same time, the larger will be the informational basis required. Therefore, the trade-off between the wish to portray a comprehensive picture of well-being and the possibility of managing the informational complexity, can only be solved by choosing a compromise alternative. Sen himself states: «the capability approach can often yield definite answers even when there is no complete agreement on the relative weights to be attached to different functionings» (Sen, 1992:46). Though CFM's evaluative space is limited to the one of achieved functionings, a balance between completeness and complexity must still be found. Therefore we have to rely on a minimum set of functionings including, in a developed society, health, education, and social interactions as main dimensions of well-being¹¹. In fact, given the openness and the flexibility of the capability framework, its operationalization is highly context-dependant, and there is no "right" or "complete" or even "better" list of functionings. It is the social, political and economic environment, the purpose of the applicative exercise, and other practical constraints which shape both the evaluative space and the relative importance of its elements. In Sen's words: «The answer to these questions [Which functionings are we to select? How do we weigh them vis-à-vis each other?] must surely depend on the purpose at hand. There is no need here for different people, making their respective judgments, to agree on the same list, or on the same weight for the different items; we are individually free to use reason as we see fit. A framework for the analysis of well-being is just that – not a complete solution of all evaluation problems, nor a procedure for interpersonal agreement on relevant judgments.» (Sen, 1996:116).

Usually multidimensional studies of well-being are mostly concerned with material living conditions, while the capability approach, especially when applied to developed countries, must deal also with relational and self-improving activities such as recreation, culture, education. As aforementioned the functionings chosen are: Physical and Psychological Health, Education and Training, and Social Interactions. In our opinion these functionings represent a good starting point to capture the complexity of well-being in developed countries, since, encompassing both material and immaterial aspects of human life, they are the basis of economic and social development and cohesion.

The aggregative issue raises interesting questions. First of all, as pointed out earlier, our *locus* of operationalization is a single (though aggregate, i.e. an administrative region) reference unit: thus avoiding the problem of aggregating diversities (functionings) among different individuals or groups¹². In fact we do not merge the achieved functionings into a synthetic index, since in a dynamic model all the elements interact, so that letting one of them vary would change the

¹¹ Some literature includes income-related functionings. In our opinion income is a means to well-being and therefore it matters only instrumentally to the extent that it can help to acquire functionings and capabilities. So in CFM we do not include income, nor any other income-related functioning.

¹² It is worth pointing out that this kind of aggregation seems to have no significance in Sen's framework, since functionings and capabilities are "properties" of individuals or of groups, in a derivative sense.

others and the whole system. An aggregate index of well-being is hence worthless, for it would hide the information given by fluctuations of the system¹³.

Anyway, in CFM we face the aggregative problem at a lower level, since we collapse the indicators in a more general dimension of well-being, i.e. the achieved functioning. We in fact move «from the space of elementary indicators to the overall evaluation of a given functioning for each unit of analysis» (Chiappero Martinetti, 2000:7). According to Sen the capability framework allows great freedom in choosing the suitable aggregative strategy: «Quite different specific theories of value may be consistent with the capability approach, and share the common feature of selecting value-objects from functionings and capabilities. Further, the capability approach can be used with different methods of determining relative weights and different mechanism for actual evaluation. The approach, if seen as a theory of algorithmic evaluation, would be clearly incomplete.» (Sen, 1993:48). Neither does the non-weighting strategy seem to be a useful aggregative route: «The varying importance of different capabilities is as much a part of the capability framework as the varying value of different commodities is a part of the real income framework. Equal valuation of all constitutive elements is needed for neither. We cannot criticize the commodity-centered evaluation on the ground that different commodities are weighted differently. Exactly the same applies to functionings and capabilities.» (Sen, 1992: 45-46). In empirical terms, in CFM we decided the relative importance of each functioning on objective grounds¹⁴, using a data-driven method independent of value judgments. More specifically, we follow the path suggested by Chiappero Martinetti (1994: 383-384) and define for each indicator of commodities determining functionings a weight w_j based on the inverse function of the frequency of the indicator itself in Italian regions:

$$w_j = \log(1/f_i) / \sum \log(1/f_i) \quad (1)$$

with $f_i > 0$ frequency of the i-th indicator under consideration¹⁵.

Therefore the essential character of the indicator is given by the diffusion it has in society: the less it is widespread, the more it is relevant. Or the less the society has it, the more the society values it. So, when an indicator shows a higher frequency of low values, the weight attached to it will be greater than the one attached to another indicator showing lower frequencies and vice versa (see *infra* 2.2 for a detailed example).

This overview of the methodological issues to be considered in the empirical application could give the impression that dealing with the somehow elusive and incomplete soul of Sen's approach involves an inescapable difficulty. But incompleteness, far from being a pretext for the persistence of the utilitarian perspective, guarantees the flexibility needed to adapt the exercise to the ever-changing context. Postponing to the next section the practical and application-oriented questions raised by CFM, there seems to be no major weakness from a methodological point of view in the process of dynamic operationalization of the capability approach. There is

¹³ We assume that a substitute of GDP is useless and misleading. Reality is too complex to be subsumed by a single number: «The passion of aggregation makes good sense in many contexts, but it can be futile or pointless in others» (Sen, 1987(b):33).

¹⁴ The adoption of a weighting scheme reflects the system of values of the society under observation. The definition of the weights by the decision-maker according to her own preferences could be another alternative. To be uncontroversial both the options share the need for certain principles of distributive justice and equity, whose consideration is beyond the reach of this work. We therefore look for acceptability on the less theoretical ground of quantitative objectivity.

¹⁵ The choice of the logarithm is intended «not to attribute an excessive importance to the indicators showing a too low frequency», as Chiappero Martinetti states (1994: n. 19, p. 384).

no doubt that well-being has a less clear-cut meaning: but complexity and ambiguity can in fact be conveniently managed without losing their strong informative potential.

2 A simple dynamic operationalization of the CFM

2.1 System dynamics and the CFM

System dynamics is basically a methodology for studying and managing the complexity of the world around us. Traditional analysis focuses on the separation of the individual element of a system. On the contrary, the central concept to system dynamics is understanding how all the objects in a system interact with one another. This means that system dynamics takes into account all the possible interactions to understand the basic structure of a system, and thus to understand the behaviors it can produce. The elements in a system can interact along a one way route or through feedback loops, where a change in one variable affects other variables over time, which in turn affect the original variable, and so on.

System dynamics constructs and tests computer simulation models, since these models can carry out the calculations needed to predict the often counterintuitive behaviors of systems. The different elements of a system must be translated into the language of system thinking. In practical terms the variables of a mental model must be translated into the following building blocks of a system dynamics model.

- *Stock*. Stocks are accumulators whose magnitudes at a point in time show how things are within the system at that point in time. In CFM commodities are represented by stocks.
- *Flow*. Flows are the rate of change of the stocks. In CFM they are the activities which build up or deplete the stocks (i.e. the commodities).
- *Converter*. Converters basically modify the flows within the system and convert inputs into outputs. But they can also represent either information or material quantities. In CFM they have both these functions. In the former they play the role of conversion factors, transforming the commodities (inputs) into functionings (outputs). In the latter they are the functionings, “score-keeping” variables whose variation over time highlight the well-being of the system at different points in time.
- *Connector*. Connectors allow information to pass between converters and converters, stocks and converters, stocks and flows, and converters and flows. They do not have numerical values, but simply transmit values between the elements of the CFM.

In figure 3 we depict the system dynamic language for a sub-system relating to a single functioning of CFM.

In general, a model is a simplified representation of a system at some particular point in time or space, intended to promote understanding of the real system. The system our model intends to represent is human well-being as intended in Sen’s capability approach. A simulation generally refers to a computerization of the developed model, which is run over time to study the implications of the defined interactions of the parts of the system. The real benefit of modeling and simulation is the ability to accomplish a time and space compression of the interrelationships within a system, bringing into view the results of interactions that would normally escape us because they are not closely related in time and space. The purpose of modelling and simulating in the CFM is to verify the variations over time of the functionings, due to the assumed variations of some elements of the system (the commodities).

Figure 3 – Stocks, flows and converters in a sub-system of the CFM

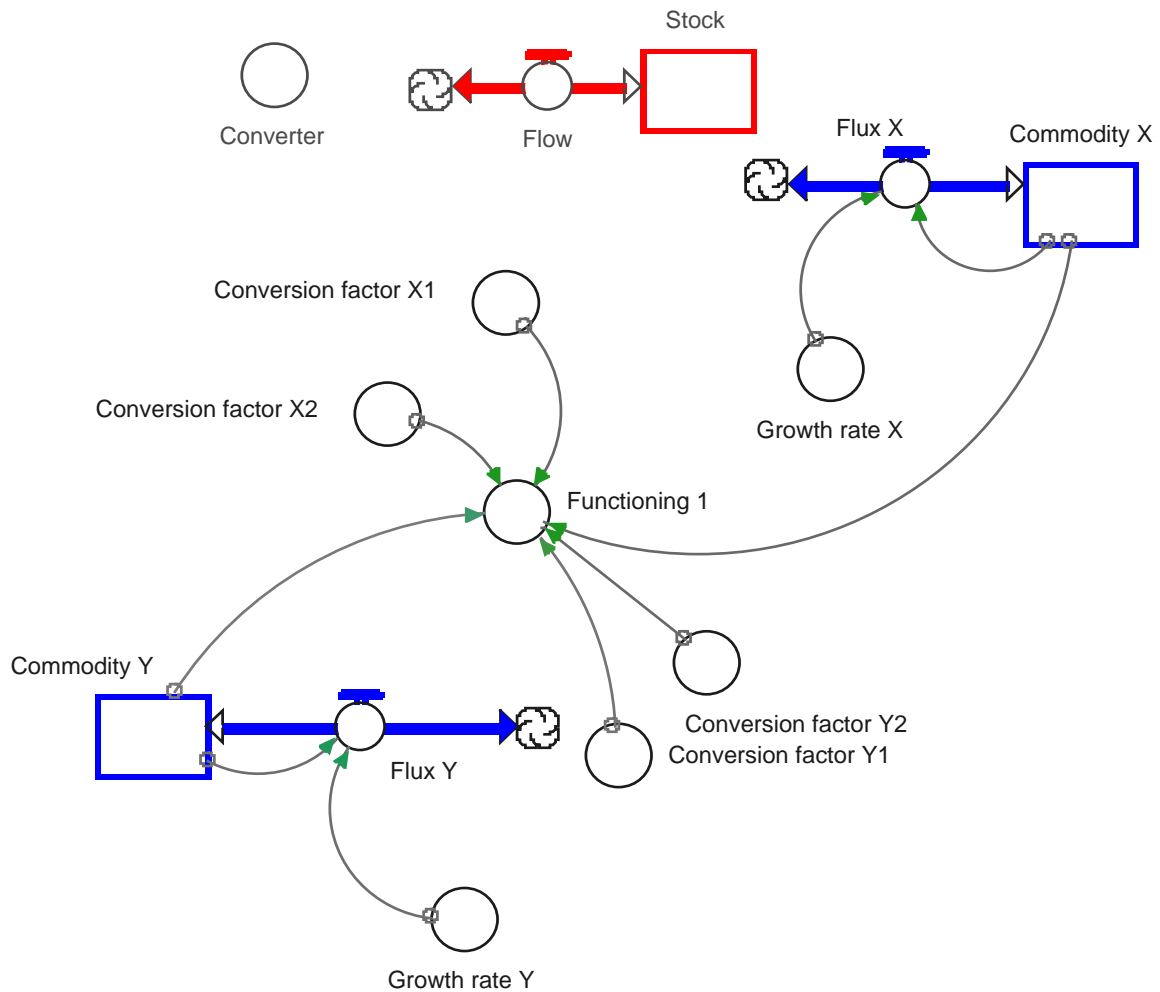

2.2 The architecture of the CFM

The CFM works in the three-dimension space of the achieved functionings: Physical and Psychological Health, Education and Training, Social Interactions. As stated before, the building blocks of the model are the commodities, the conversion factors and the functionings. From an operational perspective the CFM can be split in three sub-models, corresponding to the three different functionings, whose level of achievement is given by the conversion of the respective set of commodities. In turn the three sub-models are linked one another via positive and negative commodities relations.

In equilibrium (i.e. at the initial time) the model is essentially a snapshot based on the latest data available for the indicators (both when used as proxy of commodities and of conversion factors).

All the indicators¹⁶ refer to sub-national (i.e. Italian region) level. They are standardized (i.e. divided by regions' population) to neutralize the effect of different population size and different territorial areas, and normalized (i.e. divided by the Italian standardized average value) to make them comparable. Doing so, the value "1" represents the average Italian value for each different indicator, both in the case of commodities and of conversion factors. Thus the specific

¹⁶ We include some indicators, both as proxy of commodities and of conversion factors, which consist in subjective perception of well-being, despite the questionableness of this choice. We believe that the subjective dimension, beyond being a mere necessity, is also an opportunity to broaden the evaluative space.

standardized and normalized values determined for every indicator measure the difference – positive and negative – of the indicator under consideration from the national average. In other words, if an indicator happens to be, say, 0.947, its value is 5.3% below the national average; if it happens to be, say, 1.121, it is 12.1% above the national average. Therefore the snapshot taken reveals how much the indicators of commodities and of conversion factors differ from the average value “1”.

Having gathered data for all indicators, it is possible to convert commodities into functionings via the conversion factors, thus obtaining “converted commodities”. In fact if we consider the national average (i.e. 1) as the reference value¹⁷, the value of the conversion factors, representing the distance from the reference value, could be seen as the “magnitude” of the conversion factor for the region in analysis. Therefore if the conversion factor is supposed to facilitate the translation of a commodity into a functioning (i.e. it is favorable), the commodity itself must be multiplied by the conversion factor; on the other hand if the conversion factor hinders such a translation (i.e. it is non favorable), the commodity must be divided by the conversion factors.

Assuming for explicative purposes that only one¹⁸ commodity could determine, through conversion factors, a specific functioning, we have 4 situations:

Table 1 – The results of the conversion process

Situations	Conversion	Converted commodity
CF favorable >1	C*CF	F>C
CF favorable <1	C*CF	F<C
CF non favorable>1	C/CF	F<C
CF non favorable<1	C/CF	F>C

where:

CF= conversion factor

C = commodity

F= functioning

An example¹⁹ may be of some help. We assume, once again for explicative purposes, that the functioning “Physical and Psychological Health” (PPH) is defined only by a commodity regarding health (indicator: “Health System Employee”, i.e. the overall number of medical and paramedical employees of public and private health system in Italian regions) whose standardized and normalized value is 1.179 (i.e. 17.9% higher than Italian national average). The conversion factor favouring the translation of this commodity into the functioning PPH is good health, and the relative indicator is “Health conditions”, whose value is 1.012 (i.e. 1.2% above Italian average). The factors that hamper the conversion are the age of the population (the older, the less healthy) whose indicator is “Elderly” with value 0.927, and smoking habits, whose indicator is “Smokers” with value 1.172. Thus to convert the indicator of commodity “Health System Employee”, into the functioning PPH we must respectively multiply and divide the former by the indicator of conversion factor “Health conditions”, and by the indicators of conversion factors “Elderly” and “Smokers”:

¹⁷ The national average has no ethical meaning, it is neither “good” nor “bad” in itself.

¹⁸ In fact in CFM each functioning is determined by more converted commodities. In this case instead the converted commodity and the functioning coincide.

¹⁹ This example is a simplified excerpt of the functioning “Physical and Psychological Health” for Lombardy. The value of the functioning is merely exemplificative.

$$\begin{aligned} \text{PPH} &= \text{Health System Employee} * \text{Health condition/Elderly/Smokers} \\ &= 1.179 * 1.012 / 0.927 / 1.172 = 1.098 \end{aligned} \quad (2)$$

Knowing that 1 is also the Italian average value for all the functionings (since they are obtained multiplying and dividing indicators of commodities and conversion factors whose average value is in turn 1), the value of PPH it is thus 9.8% above Italian average.

In our model every functioning is determined by different commodities: the final value of the functioning is, as pointed out earlier (see 1.5), the weighted aggregation of the converted commodities. Besides, we assume that the attribution of weights to each functioning is based on the inverse function of the frequency of the indicators of the commodities in the Italian regions (see equation (1), section 1.5). More specifically for each indicator we determine the frequency (f_i of equation (1)) of the observation below the national average (i.e. < 1). For example, PPH is determined not only by the indicator “Health System Employee” as in the previous simplified case, but also by the indicators “Environmental Quality” (referring to the commodity environment), “Security” (referring to the commodity safety) and “Occupation” (referring to the commodity employment), whose frequency of observations below the national average are respectively 10, 12, 8, 8 (out of 20, the number of Italian regions). We can therefore calculate the respective weights in equation (1). They are:

- 0.257 for “Health System Employee” (whose frequency < 1 is 10),
- 0.278 for “Environmental Quality” (whose frequency < 1 is 12),
- 0.232 both for “Security” and “Occupation” (whose frequencies < 1 are both 8).

Knowing from the model that the converted values of the four commodities (i.e. the converted commodities) are:

- 1.018 for “Health System Employee”,
- 0.465 for “Environmental Quality”,
- 0.662 for “Security”,
- 1.936 for “Occupation”,

the value of PPH is:

$$\begin{aligned} \text{PPH} &= 0.257 * \text{Converted Health System Employee} + 0.278 * \text{Converted Environmental} \\ &\quad \text{Quality} + 0.232 * \text{Converted Security} + 0.232 * \text{Converted Occupation} \\ &= 0.257 * 1.018 + 0.278 * 0.465 + 0.232 * 0.662 + 0.232 * 1.694 \\ &= 0.937 \end{aligned} \quad (3)$$

(or 6.7% below the national average)

Finally, to put dynamism into the system we must allow its elements (i.e. the indicators) to change over time. Doing so, we can simulate the state of the system in subsequent time periods and control the elements whose evolution we are interested in – the functionings. In this tentative model the only variable elements are the commodities, which can have a positive or negative growth rate. Moreover the latter could also change the system in subsequent time periods via the positive or negative interactions with other commodities within the whole system. For instance, the relation between the commodity referred to health and the one referred to pollution is -0.014^{20} : the growth of the indicator of pollution implies a greater reduction of the indicator of health over time; the relation between occupation and safety is 0.027^{21} (the higher the employment, the safer the society); the relation between occupation and training (a commodity of the functioning Education and Training) is 0.244^{22} .

²⁰ Krzyzanowski, 2001.

²¹ Elaboration from Marselli-Vannini, 2000.

²² Laudisa, 2000.

To render the richness of the structure in the following section we analyze in detail the functioning PPH and its interrelations. But, before proceeding, we have to make clear the basic simplifying assumptions of our tentative model.

1. The choice of all elements of the model (i.e. all the indicators proxy of commodities and conversion factors) is heavily constrained by data availability. So, the indicators chosen aren't necessary the right ones, or even the most suitable: they are simply those among the available ones which, in our opinion, best fit the purposes of the experiment.
2. Both commodities and conversion factors can refer to different functionings.
3. The only indicators that can change are the ones referred to commodities. In other words the dynamism of the system depends solely on the growth rate of the indicators proxy of commodities. So, as mentioned, they are the only source of dynamism.
4. The commodities are the only elements whose change can produce variation in other commodities of the system. Therefore, positive and negative interactions within the system relate only to the relative indicators proxy of commodities.
5. The mathematical functions of these interactions are drawn from the literature, since the analysis of the available data (referring only to Lombardy) did not highlight any relation, neither linear, via a fixed effect regression analysis (with $n - 1$ dummies), nor non-linear. Therefore we derive only a limited number of interactions, ignoring the ones for which we didn't find any supporting literature.
6. All the conversion factors have equal weight and do not interact one each other.
7. The "direction" of the conversion factors is commonsensical and self-evident: we do not support it with any proof.

These assumptions²³ may seem rather restrictive or even quizzical, but we have introduced them in our exploratory simulations only for the sake of simplicity, aware that without specifications the capability approach may prove to be inapplicable. The ultimate purpose of the model, at this stage, is to verify the use of system dynamics in order to clarify knowledge and understanding of the empirical potentiality of the capability approach, and not to offer conclusive information regarding well-being, nor, for the moment, to ascertain policies that will improve system behavior. Therefore these assumptions can and should be dropped by more realistic – and complex – exercises.

²³ Behind these assumptions there are of course value judgments. Sen, though acknowledging the importance of value judgments for the practical use of the capability approach, has, once again, never specified them.

3. Physical and Psychological Health and the CFM: an insight

The CFM is based on three functionings: Physical and Psychological Health (PPH), Education and Training (ET), Social Interactions (SI). In this provisional version we analyze in depth PPH, while we consider the remaining two less thoroughly, just to simulate the whole model²⁴.

3.1 Physical and Psychological Health

Four commodities turned by a larger number of conversion factors build up the functioning PPH. In figure 4 the commodities are the stock (rectangular) variables: Health System Employees, Environmental Quality, Security and Occupation. All the other converter (circle) variables²⁵ represent the conversion factors.

Figure 4 – Physical and Psychological Health

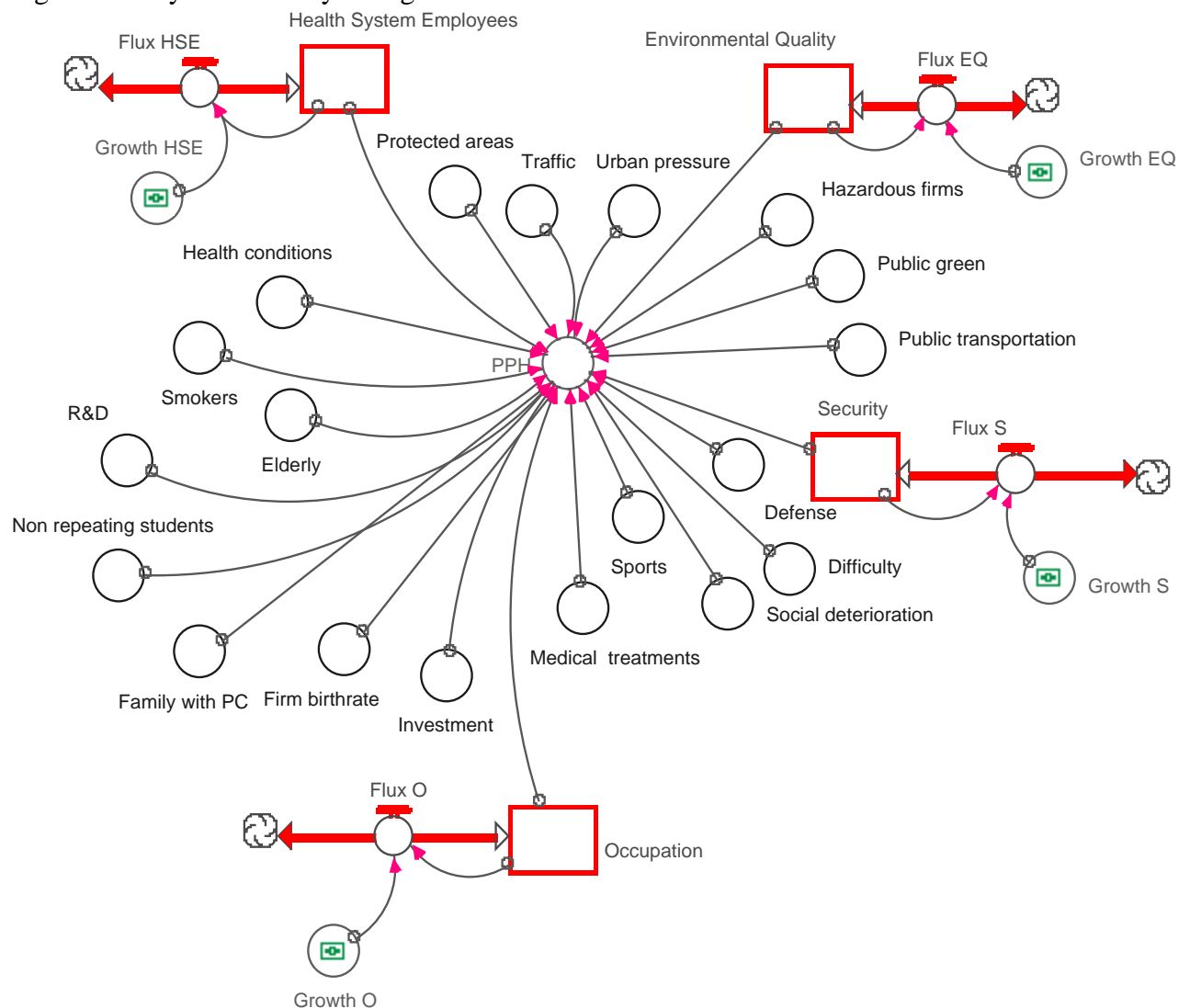

²⁴ See annex I and II.

²⁵ Except for the converter representing the functioning PPH, which has a score-keeping role and whose variation over time highlights the level of PPH at different points in time.

Health System Employees

This indicator is a determinant of well-being²⁶ and could be considered a fundamental element for the improvement of general health conditions. It refers to the overall number of medical and paramedical employees of public and private health system in Italian regions, year 1998 (source: *Annuario Statistico Regionale Lombardia (ASRL)*, table 24.04.02.03²⁷).

The related conversion factors are the following.

- Health conditions (belonging to family I personal heterogeneities – see 2.3) : percentage of people in good health, year 1999 (source: elaboration from *ASRL*, table 31.04.07). This indicator favors the conversion of the commodity into PPH, thus it is a multiplier (see 2.2, table 1) of Health System Employees.
- Medical treatments (family I): people undergoing medical treatments (source: *Istat Indagine Multiscopo 1997, Vita Quotidiana*, table 5.2). Favoring the conversion, it is a multiplier of Health System Employees.
- Sports (family I): people practicing recreational sport activities (source: *Istat Indagine Multiscopo 1997, Vita Quotidiana*, table 9.2). It is a favorable conversion factor and so a multiplier of the commodity of health.
- Elderly (family I): population over 65 years, year 2000 (source: *Istat, Demo: popolazione e statistiche demografiche*²⁸). The older the population, the more illness and disability are widespread: thus this indicator is not favorable to the conversion of the commodity into PPH and is a divisor of the commodity itself.
- Smokers (family I): people older than 14 smoking, year 1997 (source: *Istat Indagine Multiscopo 1997, Vita Quotidiana*, table 3.2). This indicator is an unfavorable conversion factor, thus the commodity is divided by it.

Table 2 – Conversion factors for Health System Employees

<i>Favorable</i>	<i>Non favorable</i>
Health conditions	Elderly
Medical treatments	Smokers
Sports	n.a.

The “converted contribution” of Health System Employees to the functioning PPH is then:

$$\frac{\text{Health System Employees} * \text{Health conditions} * \text{Medical treatments} * \text{Sports}}{\text{Elderly} / \text{Smokers}} \quad (4)$$

Environmental Quality

The commodity representing the state of the environment is Environmental Quality, and the relative indicator is the percentage of people perceiving good environmental quality, year 1999 (source: elaboration from *Istat Sistema Sanitario e Salute della Popolazione*, table 6.1²⁹). The stream of services arising from the improvement of the state of the environment are relevant to human health.

The conversion factors of Environmental Quality are the following.

²⁶ All the indicators proxy of commodities must be determinants of well- being, as stated in section 2.3.

²⁷ All the data of the *Annuario Statistico Regionale Lombardia* are downloadable from the internet: www.ring.lombardia.it

²⁸ Internet: <http://demo.istat.it/>

²⁹ The family of statistics *Sistema Sanitario e Salute della Popolazione* can be found on the Internet: <http://www.istat.it/Primpag/sociosan2001/index.html>

- Protected areas (family II): surface of protected areas (source: elaboration from *Istat Sistema Sanitario e Salute della Popolazione*, table 12.2). It favors the conversion of Environmental Quality, thus it is a multiplier.
- Public green (family II): number of families which lives close (less than 15 minutes on foot) to a park or a garden, year 1998 (source: elaboration from *ASRL*, table 57.05.08). This indicator favors the perception of Environmental Quality.
- Public transportation (family II): percentage of workers using public transportation to commute to work, year 1997 (source: *Istat Indagine Multiscopo 1997, Vita Quotidiana*, table 14.4). It is favorable to Environmental Quality.
- Hazardous firms (family II): number of potentially hazardous plants according to Italian law (DPR 175/1988, art. 4), year 1999 (source: *ASRL*, table 24.02.04.01). Hampering the conversion of the indicator of the state of the environment, it is a divisor of the latter.
- Traffic (family II): percentage of families declaring bad traffic conditions, year 1997 (source: *Istat Indagine Multiscopo 1997, Vita Quotidiana*, table 22.1). It is unfavorable to the state of the environment.
- Urban pressure (family II): percentage of urban dwellers, year 1999 (source: elaboration from *Istat Sistema Sanitario e Salute della Popolazione*, table 12.1). It hampers the conversion of Environmental Quality.

Table 3 – Conversion factors for Environmental Quality

<i>Favorable</i>	<i>Non favorable</i>
Protected areas	Hazardous firms
Public green	Traffic
Public transportation	Urban pressure

The “converted contribution” of Environmental Quality to the functioning PPH is then:

$$\frac{\text{Environmental Quality} * \text{Protected areas} * \text{Public green} * \text{Public transportation}}{\text{Hazardous firms} / \text{Traffic} / \text{Urban pressure}} \quad (5)$$

Security

The indicator chosen to represent Security concerns the percentage of people who feel safe, year 1998 (source: elaboration from *ASRL*, table 57.06.02). Security is a determinant of well-being, for it accrues the livability of a community.

The conversion factors of Security are the following.

- Defense (family III social conditions): number of family who installed security systems, year 1998 (source: *ASRL*, table 31.06.01.01). This indicator suggests an improvement in Security, thus it is a multiplier.
- Difficulty (family III): difficulty to reach police stations, year 1998 (source: *Istat, Indicatori regionali per la valutazione delle politiche di sviluppo*, table V.04). It is unfavorable to Security.
- Social deterioration (family III): percentage of people over 14 perceiving social deterioration (source: *ASRL*, table 57.06.03). It hampers the conversion of Security.

Table 4 – Conversion factors for Security

<i>Favorable</i>	<i>Non favorable</i>
------------------	----------------------

Defense	Difficulty
n.a.	Social deterioration

The “converted contribution” of Security to the functioning PPH is then:

$$\text{Security} * \text{Defense} / \text{Difficulty} / \text{Social deterioration} \quad (6)$$

Occupation

Occupation is very important for human well-being. Unemployment, as pointed out by Sen (1997:160-161), produces penalties for individuals other than low income, such as: loss of freedom and social exclusion, psychological harm, ill health and mortality, loss of human relation and family life. Traditionally the employment indicators are constituent (i.e. output) of well-being. In the present exercise the occupational level has very extensive extra-income meanings, thus it can be considered a determinant of well-being. The indicator used is the 15-64 employment rate, year 2001 (source: *Istat, Indagine sulla forza di lavoro*³⁰). The related conversion factors are the following.

- Family with PC (family III): number of families owning a PC, year 2000 (source: *ASRL*, table 57.01.09). This indicator favors Occupation.
- Firm birth-rate (family III): net firm birth-rate, year 2001 (source: *Istat, Indicatori regionali per la valutazione delle politiche di sviluppo*, table IV.20). It represents the vitality of the business system, thus favoring the conversion of Occupation.
- Investment (family III): net fixed investment on GDP, year 1999 (source: *Istat, Indicatori regionali per la valutazione delle politiche di sviluppo*, table IV.11). Investments, in general, are supposed to increase the possibility of employment, so this indicator is a multiplier of Occupation.
- Non repeating students (family I): percentage of non-repeating students, year 1998-99 (source: *Istat, Indagine scuola secondaria 2002*). This personal conversion factor testifies the ability of individuals and thus is supposed to favor the possibility of employment.
- R&D (family III): research and development on GDP, year 1999 (source: *Istat, Indicatori regionali per la valutazione delle politiche di sviluppo*, table III.12). Like the previous conversion factor, R&D is supposed to increase Occupation.
- Social deterioration (family III): percentage of people over 14 perceiving social deterioration (source: *ASRL*, table 57.06.03). It hampers the conversion of Occupation.

Table 5 – Conversion factors for Occupation

<i>Favorable</i>	<i>Non favorable</i>
Family with PC	Social deterioration
Firm birth-rate	n.a.
Investment	n.a.
Non repeating students	n.a.
R&D	n.a.

The “converted contribution” of Occupation to the functioning PPH is then:

$$\text{Occupation} * \text{Family with PC} * \text{Firm birth-rate} * \text{Investment} *$$

³⁰ Internet: <http://www.istat.it/Anumital/Astatset/lav.htm>

3.2 The use of public expenditure indicators in PPH

We consider also an alternative scenario in which the four commodities of figure 4 are represented by the level of public expenditure³¹. In this setting the indicators of PPH become the amount of public expenditure³² relating to each specific functional sector (i.e. health, environmental quality, safety, and occupation). This alternative could prove very useful for policy-makers, because it allows to run the simulations by varying only public expenditure, a very common policy tool. Moreover, comparing the results with those given by socio-economic indicators, it is possible to point out the degree of conversion of public expenditure into well-being.

In detail we use the following regional figures³³:

- health expenses (COFOG 07) for health level;
- environmental protection expenses (COFOG 05) for environmental quality;
- public order and safety expenses (COFOG 03) for safety;
- economic affairs expenditures (COFOG 04) for occupation³⁴.

Public expenditure indicators are determinant of well-being, according to the point of section 2.3.

4 Running the simulations

To test the CFM we ran different simulations for three regions: Lombardy, Emilia Romagna and Campania. This choice is suggested by *per capita* GDP and quality of life rankings (based on Grasso, 2002: table 5³⁵, p. 286) of the Italian regions. In doing so we compare a rich and important region (Lombardy), whose ranking of quality of life is noticeably lower than the one in terms of GDP, with another high-income region with the highest quality of life (Emilia Romagna), and with one of the lower-income regions, characterized by the lowest ranking of quality of life (Campania). The results of the simulations are given for the functioning Physical and Psychological Health – both when the commodities are the socio-economic indicators of section 3.1, and when these are the indicators of public expenditure of section 3.2 – and for the whole CFM³⁶. We sketch for demonstrative purposes, two simulations – out of the infinite feasible – on a three-year (twelve quarters) time horizon: one in which all the commodities have a steady positive growth rate of 2.4% per year (0.6% per quarter), and one with a steady negative growth rate of 2.4% per year.

³¹ In this provisional model we don't change the conversion factors according to the changed commodities. On the other hand we change the weight attached to each indicator according to the new inverse function of frequency of the indicators of public expenditure.

³² We follow the functional classification of expense used by Istat (see Istat, *I conti della pubblica amministrazione*, table 17), which is derived from UN COFOG (United Nations Classification of Expenditure According to Purpose – New York, 2000).

³³ Drawn from *Annuario Statistico Regionale Lombardia*, table 50.08.02.01.

³⁴ Employment is produced directly by both the private and public sectors. Moreover some public expenditure can favour the production of employment by the private sector. For this reason we consider the whole Division 04 – Economic Affairs of COFOG, which is composed by 04.1 general economic commercial and labour affairs, 04.2 agricultural, forestry, fishing and hunting, 04.3 fuel and energy, 04.4 mining, manufacturing and construction, 04.5 transport, 04.6 communication, 04.7 other industries, 04.8 R&D, 04.9 economic affairs n.e.c.

³⁵ According to the findings of this work, Lombardy is third (out of twenty regions) in term of *per capita* GDP and tenth in term of quality of life, while Emilia Romagna is respectively second and first, and Campania nineteenth and twentieth.

³⁶ The simulations regarding Education and Training, and Social Interactions are summarized in annex III and IV. They are necessary to simulate the whole CFM, but the two functionings are considered less comprehensively than the functioning which represents our main focus, i.e. Physical and Psychological Health.

4.1 Physical and Psychological Health: socio-economic indicators

At initial time ($t = 0$), when the commodities are represented by socio-economic indicators, the functioning Physical and Psychological Health has the values³⁷ reported in the following table.

Table 6 – Physical and Psychological Health

Values	Lombardy	Emilia R.	Campania
PPH	0.854	1.018	0.563
PPH vs. average	-14.55%	1.77%	-43.71%

Legenda:

PPH = absolute value of the functioning

PPH% vs. average = percentage variance of the functioning from national average

We hereafter report the results of the two explicative sets of simulations with steady positive and negative growth rates for all the commodities.

Simulation A

Steady positive growth rate of 2.4% per year (0.6% per quarter) for all the commodities.

Table 7 – Lombardy

Time	PPH	PPH% vs. average	% increase
0	0.854	-14.55	n.a.
1	0.856	-14.38	0.20
2	0.858	-14.21	0.40
3	0.860	-14.04	0.61
4 (year 1)	0.861	-13.86	0.81
5	0.863	-13.68	1.03
6	0.865	-13.49	1.24
7	0.867	-13.30	1.46
8 (year 2)	0.869	-13.11	1.69
9	0.871	-12.92	1.91
10	0.873	-12.72	2.14
11	0.875	-12.52	2.38
12 (year 3)	0.877	-12.32	2.62

Legenda:

PPH% vs. average = percentage variance of the functioning from national average

% increase = percentage increase of the functioning over the time horizon

³⁷ All the simulations are run with Ithink® 6.0 software.

Table 8 – Emilia Romagna

Time	PPH	PPH% vs. average	% increase
0	1.018	1.77	n.a.
1	1.018	1.81	0.04
2	1.019	1.86	0.09
3	1.019	1.91	0.14
4 (year 1)	1.020	1.96	0.19
5	1.020	2.02	0.25
6	1.021	2.08	0.31
7	1.021	2.15	0.37
8 (year 2)	1.022	2.21	0.44
9	1.023	2.29	0.51
10	1.024	2.36	0.58
11	1.024	2.44	0.66
12 (year 3)	1.025	2.53	0.74

Table 9 – Campania

Time	PPH	PPH% vs. average	% increase
0	0.563	-43.71	n.a.
1	0.564	-43.60	0.20
2	0.565	-43.49	0.40
3	0.566	-43.38	0.60
4 (year 1)	0.567	-43.26	0.81
5	0.569	-43.14	1.02
6	0.570	-43.02	1.24
7	0.571	-42.90	1.45
8 (year 2)	0.572	-42.77	1.68
9	0.574	-42.64	1.90
10	0.575	-42.51	2.13
11	0.576	-42.38	2.37
12 (year 3)	0.578	-42.25	2.60

Simulation B

Steady negative growth rate of 2.4% per year (0.6% per quarter) for all the commodities.

Table 10 – Lombardy

Time	PPH	PPH% vs. average	% decrease
0	0.854	-14.55	n.a.
1	0.853	-14.72	0.20
2	0.851	-14.88	0.39
3	0.850	-15.04	0.58
4 (year 1)	0.848	-15.20	0.76
5	0.846	-15.36	0.94
6	0.845	-15.51	1.12
7	0.843	-15.66	1.29
8 (year 2)	0.842	-15.80	1.46
9	0.841	-15.95	1.63
10	0.839	-16.09	1.79
11	0.838	-16.22	1.95
12 (year 3)	0.836	-16.36	2.11

Legenda:

PPH% vs. average = percentage variance of the functioning from national average

% decrease = percentage decrease of the functioning over the time horizon

Table 11 – Emilia Romagna

Time	PPH	PPH% vs. average	% decrease
0	1.018	1.77	n.a.
1	1.017	1.73	0.04
2	1.017	1.69	0.08
3	1.017	1.66	0.11
4 (year 1)	1.016	1.63	0.14
5	1.016	1.61	0.16
6	1.016	1.58	0.18
7	1.016	1.57	0.20
8 (year 2)	1.016	1.55	0.21
9	1.015	1.54	0.23
10	1.015	1.53	0.23
11	1.015	1.53	0.24
12 (year 3)	1.015	1.53	0.24

Table 12 – Campania

Time	PPH	PPH% vs. average	% decrease
0	0.563	-43.71	n.a.
1	0.562	-43.82	0.19
2	0.561	-43.93	0.38
3	0.560	-44.04	0.57
4 (year 1)	0.559	-44.14	0.76
5	0.558	-44.24	0.94
6	0.557	-44.34	1.11
7	0.556	-44.44	1.28
8 (year 2)	0.555	-44.53	1.45
9	0.554	-44.63	1.62
10	0.553	-44.72	1.78
11	0.552	-44.81	1.94
12 (year 3)	0.551	-44.89	2.09

PPH is below national average in Lombardy and Campania, while it is slightly above average in Emilia Romagna. It spans from -15% in Lombardy, to a significant -44% in Campania. These values may be considered rather consistent with the ranking of these two regions in terms of quality of life (respectively tenth and twentieth). Quite surprisingly Emilia Romagna's value, though positive (2%), doesn't seem to validate its first place in quality of life. Moreover, the positive growth simulations run seem to improve quite noticeably PPH both for Lombardy and Campania (which are both 2.6% higher at the end of the time horizon), and to have scarce impact on Emilia Romagna (0.7% after three years). Similar evidence are brought by the negative growth simulations, where the values at the end of the period of analysis are -2.1% for Lombardy and Campania, and -0.2% for Emilia Romagna. In general it is interesting to point out that with a 7.2% increase of all the indicators of commodities over three years (2.4% per year), the maximum increase of PPH is only about one third (2.6%).

4.2 Physical and Psychological Health: indicators of public expenditure

As stated above, besides representing an alternative measure of the functioning, PPH measured on public expenditure indicators can be interpreted as the reference point to valuate the degree of conversion of public expenditure into well-being.

When the commodities are represented by indicators of public expenditure, the functioning Physical and Psychological Health has, at initial time, the values reported in the following table.

Table 13 – Physical and Psychological Health

Values	Lombardy	Emilia R.	Campania
PPH	0.710	0.944	0.570
PPH vs. average	-29.00%	-5.62%	-43.04%

Legenda:

PPH = absolute value of the functioning

PPH% vs. average = percentage variance of the functioning from national average

The results of the two explicative sets of simulations with steady positive and negative growth rates for all the commodities are reported below.

Simulation C

Steady positive growth rate of 2.4% per year (0.6% per quarter) for all the commodities.

Table 14 – Lombardy

Time	PPH	PPH% vs. average	% increase
0	0.710	-29.00	n.a.
1	0.711	-28.90	0.13
2	0.712	-28.81	0.27
3	0.713	-28.71	0.40
4 (year 1)	0.714	-28.61	0.55
5	0.715	-28.51	0.69
6	0.716	-28.40	0.84
7	0.717	-28.29	0.99
8 (year 2)	0.718	-28.18	1.15
9	0.719	-28.07	1.31
10	0.721	-27.95	1.47
11	0.722	-27.83	1.64
12 (year 3)	0.723	-27.71	1.81

Legenda:

PPH% vs. average = percentage variance of the functioning from national average

% increase = percentage increase of the functioning over the time horizon

Table 15 – Emilia Romagna

Time	PPH	PPH% vs. average	% increase
0	0.944	-5.62	n.a.
1	0.944	-5.60	0.26
2	0.944	-5.57	0.55
3	0.945	-5.54	0.89
4 (year 1)	0.945	-5.50	0.13
5	0.945	-5.46	0.17
6	0.946	-5.42	0.21
7	0.946	-5.37	0.26
8 (year 2)	0.947	-5.32	0.32
9	0.947	-5.27	0.38
10	0.948	-5.21	0.44
11	0.949	-5.15	0.50
12 (year 3)	0.949	-5.08	0.57

Table 16 – Campania

Time	PPH	PPH% vs. average	% increase
0	0.570	-43.04	n.a.
1	0.571	-42.95	0.16
2	0.571	-42.85	0.33
3	0.572	-42.76	0.50
4 (year 1)	0.573	-42.66	0.68
5	0.574	-42.56	0.86
6	0.575	-42.45	1.04
7	0.577	-42.35	1.22
8 (year 2)	0.578	-42.24	1.41
9	0.579	-42.13	1.61
10	0.580	-42.02	1.80
11	0.581	-41.90	2.00
12 (year 3)	0.582	-41.79	2.21

Simulation D

Steady negative growth rate of 2.4% per year (0.6% per quarter) for all the commodities.

Table 17 – Lombardy

Time	PPH	PPH% vs. average	% decrease
0	0.710	-29.00	n.a.
1	0.709	-29.09	0.13
2	0.708	-29.18	0.25
3	0.707	-29.26	0.37
4 (year 1)	0.707	-29.35	0.49
5	0.706	-29.43	0.61
6	0.705	-29.51	0.72
7	0.704	-29.58	0.82
8 (year 2)	0.703	-29.65	0.93
9	0.703	-29.73	1.03
10	0.702	-29.79	1.12
11	0.701	-29.86	1.22
12 (year 3)	0.701	-29.92	1.30

Legenda:

PPH% vs. average = percentage variance of the functioning from national average

% decrease = percentage decrease of the functioning over the time horizon

Table 18 – Emilia Romagna

Time	PPH	PPH% vs. average	% decrease
0	0.944	-5.62	n.a.
1	0.944	-5.64	0.23
2	0.943	-5.66	0.41
3	0.943	-5.67	0.56
4 (year 1)	0.943	-5.68	0.66
5	0.943	-5.69	0.73
6	0.943	-5.69	0.75
7	0.943	-5.69	0.73
8 (year 2)	0.943	-5.69	0.68
9	0.943	-5.68	0.58
10	0.943	-5.66	0.45
11	0.944	-5.65	0.27
12 (year 3)	0.944	-5.63	0.57

Table 19 – Campania

Time	PPH	PPH% vs. average	% decrease
0	0.570	-43.04	n.a.
1	0.569	-43.14	0.16
2	0.568	-43.23	0.32
3	0.567	-43.31	0.47
4 (year 1)	0.566	-43.40	0.62
5	0.565	-43.48	0.77
6	0.564	-43.56	0.91
7	0.564	-43.64	1.05
8 (year 2)	0.563	-43.72	1.19
9	0.562	-43.80	1.32
10	0.561	-43.87	1.45
11	0.561	-43.94	1.58
12 (year 3)	0.560	-44.01	1.70

The evidence from this set of public expenditure indicators is similar to that from socio-economic ones. PPH is far below the national average for Lombardy (-29%) and Campania (-43%), while it is only slightly below for Emilia Romagna (-5%). The main difference with the previous findings lies in the values of Lombardy, which has roughly doubled its distance from national average, thus showing a significant capacity of turning public expenditure into well-being (or at least in a relevant component of well-being). The values from the simulations run, both with positive and negative growth rates, have approximately the same magnitude as the ones derived from socio-economic indicators.

4.3 Socio-economic indicators vs. public expenditure indicators

In CFM indicators represent the commodities necessary to achieve functionings. Therefore when the model is run with different sets of indicators, the value of the functioning changes. So the values of PPH based on socio-economic indicators is different from the values based on public expenditure indicators.

In the following three tables are reported the values of PPH for both the sets of indicators and the percentage variation of the former with respect to the latter, under the same hypotheses of Simulation A and C of sections 4.1 e 4.2.

Table 20 – Lombardy: SE vs. PE indicators

Time	PPH SE	PPH PE	SE/PE
0	0.854	0.710	20.28
1	0.856	0.711	20.39
2	0.858	0.712	20.51
3	0.860	0.713	20.62
4 (year 1)	0.861	0.714	20.59
5	0.863	0.715	20.70
6	0.865	0.716	20.81
7	0.867	0.717	20.92
8 (year 2)	0.869	0.718	21.03
9	0.871	0.719	21.14
10	0.873	0.721	21.08
11	0.875	0.722	21.19
12 (year 3)	0.877	0.723	21.30

Legenda:

PPH SE = PPH with socio-economic indicators of commodities

PPH PE = PPH with public expenditure indicators of commodities

SE/PE = percentage variation between PPH SE and PPH PE

Table 21 – Emilia Romagna: SE vs. PE indicators

Time	PPH SE	PPH PE	SE/PE
0	1.018	0.944	7.84
1	1.018	0.944	7.84
2	1.019	0.944	7.94
3	1.019	0.945	7.83
4 (year 1)	1.020	0.945	7.94
5	1.020	0.945	7.94
6	1.021	0.946	7.93
7	1.021	0.946	7.93
8 (year 2)	1.022	0.947	7.92
9	1.023	0.947	8.03
10	1.024	0.948	8.02
11	1.024	0.949	7.90
12 (year 3)	1.025	0.949	8.01

Table 22 – Campania: SE vs. PE indicators

Time	PPH SE	PPH PE	SE/PE
0	0.563	0.570	-1.23
1	0.564	0.571	-1.23
2	0.565	0.571	-1.05
3	0.566	0.572	-1.05
4 (year 1)	0.567	0.573	-1.05
5	0.569	0.574	-0.87
6	0.570	0.575	-0.87
7	0.571	0.577	-1.04
8 (year 2)	0.572	0.578	-1.04
9	0.574	0.579	-0.86
10	0.575	0.580	-0.86
11	0.576	0.581	-0.86
12 (year 3)	0.578	0.582	-0.69

In general, when the SE/PE index is positive the regions can be considered good users of public expenditure, and vice versa when the index is negative. In other words, assuming that public expenditure is an important underpinning of well-being, when well-being measured by functioning based on socio-economic indicators is higher than the one measured via public expenditure indicators, we hold that public expenditure has been properly utilized to improve well-being.

In our model both Lombardy and Emilia Romagna have positive SE/PE, while Campania shows a negative value. Lombardy's average value is about 20, meaning that the degree of conversion of public expenditure is very high. Emilia Romagna's is lower (about 8), thus public expenditure seems to be less effectively used. Finally, the negative degree of conversion of public expenditure in Campania seems to demonstrate a failure of public action, which could also partly explain the low level of absolute PPH in that region.

4.4 CFM

Finally we simulate the whole CFM³⁸ for the region analyzed, under the usual hypothesis of steady positive and negative growth. The values of the functionings are different from the ones calculated in every specific sub-model (see 4.1, annex III, annex IV), owing to the interactions within the commodities of the different sub-models. In the present test these interactions are quite limited and their mathematical function is taken from the literature. For example the relation between the commodity Occupation (functioning PPH) and the commodity Training (functioning Education and Training) is 0.244, according to Laudisa (2000). Future refinements of CFM cannot escape the necessity of considering more thoroughly all the possible interactions within the model, in order to formalize the appropriate functions.

³⁸ PPH is based on socio-economic indicators; ET and SI are sketched in the annexes.

Table 23 – Lombardy

Time	PPH	ET	SI
Initial	0.854	1.114	0.772
Final (positive growth)	0.868	1.197	0.814
Final (negative growth)	0.836	1.037	0.747

Legenda:

PPH = Physical and Psychological Health

ET = Education and Training

SI = Social Interactions

Table 24 – Emilia Romagna

Time	PPH	ET	SI
Initial	1.018	1.508	1.601
Final (positive growth)	1.046	1.621	1.677
Final (negative growth)	0.993	1.404	1.529

Table 25 – Campania

Time	PPH	ET	SI
Initial	0.563	0.291	0.279
Final (positive growth)	0.563	0.313	0.293
Final (negative growth)	0.564	0.271	0.266

In general all the regions seem to confirm their ranking in term of quality of life according to Grasso, 2002. Lombardy reveals two functionings below average (PPH and SI) and only ET above, Emilia Romagna presents all the functionings above average (especially ET and SI), and Campania has very poor values particularly for ET and SI. The positive and negative growth patterns, pointed out by the simulations run, are more relevant at aggregate level for Emilia Romagna, while they appear weaker for Lombardy and almost irrelevant for Campania.

5. Concluding remarks

In PPH, the values derived for Lombardy and Campania hint at a good level of consistency with the ranking of these regions in terms of quality of life. Emilia Romagna's values, conversely, are not coherent with this latter ranking. When considering the whole CFM all the regions seem to confirm their ranking in term of quality of life, their functionings values spreading from high above the national average for Emilia Romagna, to well below for Campania, which are respectively first and last in terms of quality of life.

Furthermore, the model seems to suggest that Lombardy, the Italian region of oldest industrialization, is still paying the costs of a pattern of economic growth which, by privileging utilitarian welfare, has forgotten the senian dimensions of well-being. Emilia Romagna, maybe learning from the mistakes of first-movers, has followed a more sustainable model of development, which has allowed higher values for all the functionings considered. Campania, also according to the senian paradigm, confirms the general delay of southern Italy.

From a different point of view, when determining PPH via public expenditure indicators, Lombardy and Emilia Romagna show lower values, attesting their capacity of turning public expenditure into well-being improvement. On the contrary the negative degree of conversion of public expenditure in Campania seems to demonstrate a failure of public policies, which could in part explain also the low level of absolute well-being in that region. Therefore, the use of public expenditure as a tool to improve well-being could prove more effective in the two northern regions.

Finally the positive and the negative growth simulations run over a three-year time-span, seem to affect rather markedly PPH both for Lombardy and Campania, and to have scarce impact on Emilia Romagna. On the contrary at aggregate level the variations are stronger for the latter region, while they appear weaker for Lombardy and almost irrelevant for Campania. In general it is however interesting to point out that with a 7.2% increase of all the commodities over three years, the maximum increase of PPH is only about one third (2.6%).

The main purpose of this paper was to test system dynamics to operationalize Sen's capability approach. According to the evidence of the models and of the simulations run, we think that our attempts are quite consistent with Sen's view to well-being operationalization, in which commodities (and incomes) are only the material basis. Well being in fact depends on a number of personal and social circumstances that can usefully be internalized in a systemic model. Therefore we believe that the strength of this operative approach lies in the fact that it consents an objective verification of the variations over time of the functionings, due to the assumed variations of some elements of the system (the commodities), filtered by the conversion factors.

Annex I – Education and Training

Education and training are important conditions for increasing the individuals' control over the reality they live and for improving their self-esteem. The commodities that signify the functioning Education and Training are School Teachers, Cultural and Recreational Expenses and Training.

Figure I.I – Education and Training

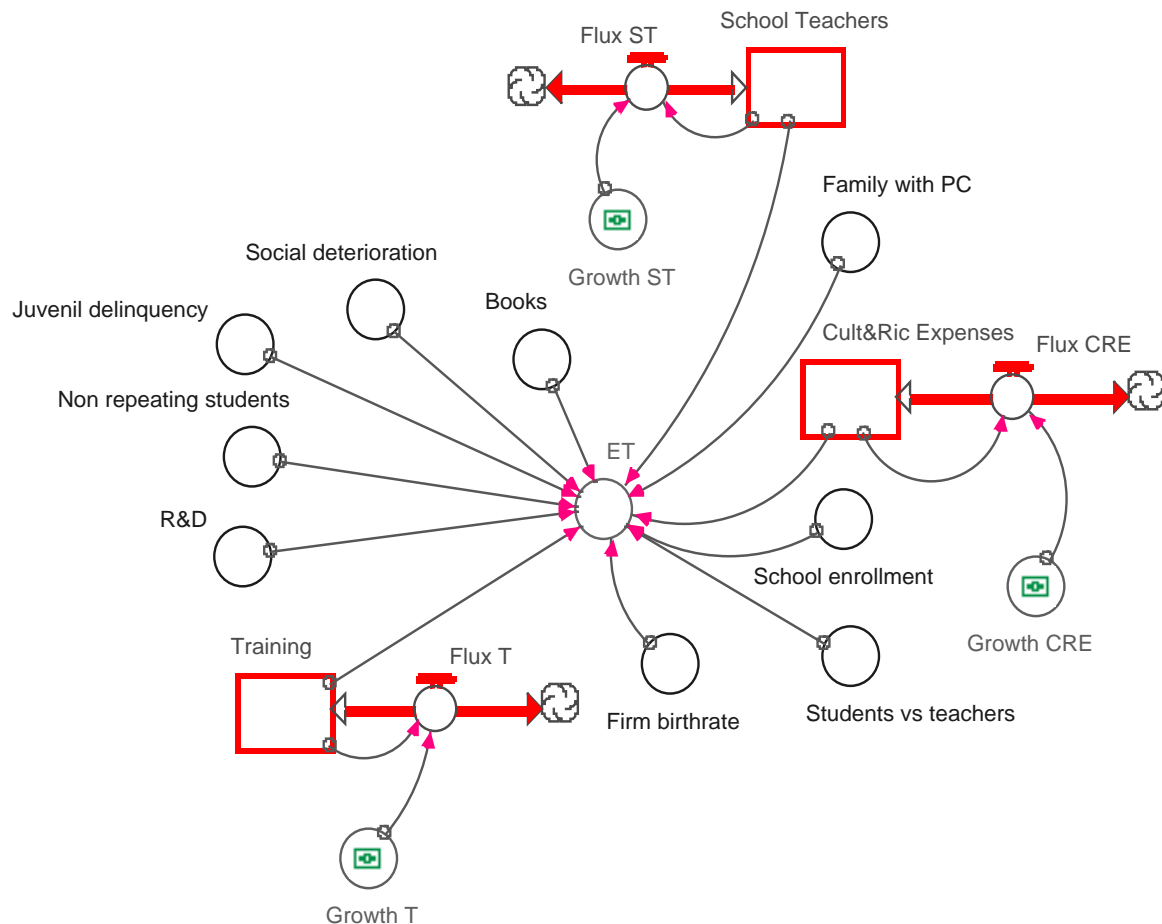

School Teachers

The indicator School Teachers is the number of total school teachers, year 1998-99 (source: elaboration from ASRL, tables, 24.05.02.03, 24.05.03.01, 24.05.04.02). This indicator is a proxy of education and a determinant of well-being. It is corrected by the following conversion factors.

- Books (family I): people over 6 who have read at least a book in the last 12 months, year 2000 (source: ASRL, table 31.02.02). The books are supposed to favor education.
- Family with PC (family III): number of families owning a PC, year 2000 (source: ASRL, table 57.01.09). This indicator favors the conversion of School Teacher.
- Non repeating students (family I): percentage of non-repeating students, year 1998-99 (source: Istat, *Indagine scuola secondaria 2002*). This personal conversion factor is supposed to favor education.
- School enrollment (family 3): high school enrollment rate, year 1997 (source: Istat, *Demos-Sistema di indicatori sociali*³⁹, table 13). This indicator favors the conversion of School Teachers.

³⁹ Internet: <http://www.istat.it/Primpag/demos/demos.htm>

- Juvenile delinquency (family III): minors denounced, year 1997 (source: *Istat, Demos-Sistema di indicatori sociali*, table 13). It hampers education.
- Social deterioration (family III): percentage of people over 14 perceiving social deterioration (source: *ASRL*, table 57.06.03). It hampers the conversion of education.
- Students vs. teacher (family III): number of students for teacher, year 1998-99 (source: *Istat, Indagine scuola secondaria*, 2002). The higher the ratio, the more difficult the conversion of the indicator of education.

Table I.1 – Conversion factors for School Teachers

<i>Favorable</i>	<i>Non favorable</i>
Books	Juvenile delinquency
Family with PC	Social deterioration
Non repeating students	Stud vs. teach
School enrollment	n.a.
R&D	n.a.

The “converted contribution” of School Teachers to the functioning ET is then:

$$\text{School Teachers} * \text{Books} * \text{Family with PC} * \text{Non repeating students} * \text{School enrollment} * \text{R\&D} / \text{Juvenile delinquency} / \text{Social deterioration} / \text{Stud vs. teach} \quad (\text{I.A})$$

Cultural and Recreational Expenses

This indicator, determinant of well-being, is a proxy of education and consists in the percentage of cultural and recreational domestic consumption as to total domestic consumption, year 1999 (source: *Istat, Indicatori regionali per la valutazione delle politiche di sviluppo*, table II.06). The conversion factors are the following.

- Books (family I): people over 6 who have read at least a book in the last 12 months, year 2000 (source: *ASRL*, table 31.02.02). The books are supposed to be favorable.
- Family with PC (family III): number of families owning a PC, year 2000 (source: *ASRL*, table 57.01.09). This indicator favors the conversion of Cultural and Recreational Expenses.
- Non repeating students (family I): percentage of non-repeating students, year 1998-99 (source: *Istat, Indagine scuola secondaria 2002*). This personal conversion factor is supposed to favor education.
- Social deterioration (family III): percentage of people over 14 perceiving social deterioration (source: *ASRL*, table 57.06.03). It hampers the conversion of education.

Table I.2 – Conversion factors for Cultural and Recreational Expenses

<i>Favorable</i>	<i>Non favorable</i>
Books	Social deterioration
Family with PC	n.a.
Non repeating students	n.a.

The “converted contribution” of Cultural and Recreational Expenses to the functioning ET is then:

Cultural and Recreational Expenses * Books * Family with PC * Non repeating students / Social deterioration (I.B)

Training

This indicator is the number of professional training courses as compared to the number of employed aged 15-64, year 1996 (source: elaboration from ASRL, table 25.05.05.02). It's a determinant of well-being. The conversion factors are the following.

- Family with PC (family III): number of families owning a PC, year 2000 (source: ASRL, table 57.01.09). This indicator favors the conversion of Training.
- Firm birth-rate (family III): net firm birth-rate, year 2001 (source: Istat, *Indicatori regionali per la valutazione delle politiche di sviluppo*, table IV.20). It represents the vitality of the business system, thus favoring the conversion of Training.
- Non repeating students (family D): percentage of non-repeating students, year 1998-99 (source: Istat, *Indagine scuola secondaria 2002*). This personal conversion factor is supposed to favor Training.
- R&D (family III): research and development on GDP, year 1999 (source: Istat, *Indicatori regionali per la valutazione delle politiche di sviluppo*, table III.12). Like the previous conversion factor, R&D is supposed to improve the effectiveness of training activities.
- Juvenile delinquency (family III): minors denounced, year 1997 (source: Istat, *Demos-Sistema di indicatori sociali*, table 13). It hampers Training.

Table I.3 – Conversion factors for Training

<i>Favorable</i>	<i>Non favorable</i>
Family with PC	Juvenile delinquency
Firm birth-rate	n.a.
Non repeating students	n.a.
R&D	n.a.

The “converted contribution” of Training to the functioning ET is then:

Training * Family with PC * Firm birth-rate * Non repeating students / Juvenile delinquency (I.C)

Annex II - Social Interactions

To portray a credible picture of well-being in a developed society we must include a functioning related to social interactions. The commodity base of this functioning is constituted by voluntary activities, by safeness (Security is the same commodity used in PPH), and by cultural and recreational engagement (relying on the same commodity of ET: Cultural and Recreational Expenses).

Figure II.I – Social Interactions

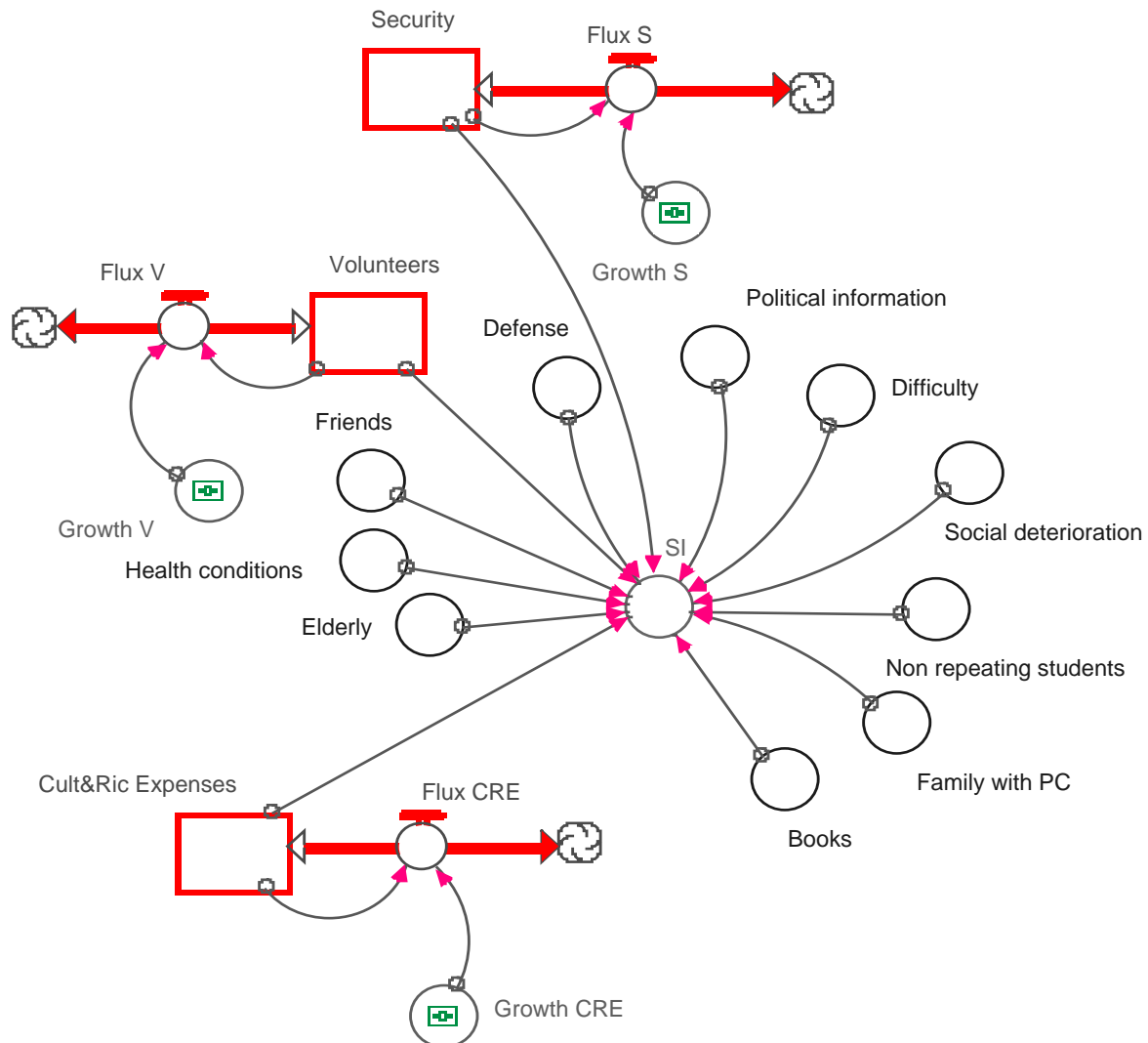

Volunteers

This indicator represents civil involvement: it consists in fact in the number of volunteer association, year 1999 (source: *Istat, le associazioni di volontariato in Italia*⁴⁰). It is a determinant of well-being, whose conversion factors are the following.

- Friends (family III): people over 6 who meet friends at least once in a week, year 2000 (source: *ASRL, table 31.02.14*). This indicator favors the conversion of Volunteers.
- Health conditions (family I) : percentage of people in good health, year 1999 (source: elaboration from *ASRL, table 31.04.07*). This indicator is a multiplier of Volunteers.

⁴⁰ Internet: <http://www.istat.it/Anotizie/Aaltrein/statinbrev/volont99/index.html>

- Political information (family III): people over 14 who are informed about Italian politics (source: *ASRL*, table 57.02.11). This indicator favors the conversion of Volunteers.
- Difficulty (family III): difficulty to reach police stations, year 1998 (source: *Istat, Indicatori regionali per la valutazione delle politiche di sviluppo*, table V.04). It is unfavorable to Volunteers.
- Elderly (family I): population over 65 years, year 2000 (source: *Istat, Demo: popolazione e statistiche demografiche*⁴¹). The older the population, the more difficult is interaction: thus this indicator is not favorable to the conversion of Volunteers.
- Social deterioration (family III): percentage of people over 14 perceiving social deterioration (source: *ASRL*, table 57.06.03). It hampers the conversion of Volunteers.

Table II.1 – Conversion factors for Volunteers

<i>Favorable</i>	<i>Non favorable</i>
Friends	Difficulty
Health conditions	Elderly
Political information	Social deterioration

The “converted contribution” of Volunteers to SI is then:

$$\text{Volunteers} * \text{Friends} * \text{Health conditions} * \text{Political information} / \text{Difficulty} / \text{Elderly} / \text{Social deterioration} \quad (\text{II.A})$$

Security

This commodity is the same as in PPH (section 3.1). The indicator chosen concerns the percentage of people feeling safe, year 1998 (source: elaboration from percentage of people over 14 feeling unsafe, *ASRL*, table 57.06.02). Security is a determinant of well-being, for it increases the livability of a community.

The conversion factors of Security are, once again, the same as in PPH: Defense, Difficulty, Social deterioration (see table 4).

The “converted contribution” of Security to the functioning SI is then:

$$\text{Security} * \text{Defense} / \text{Difficulty} / \text{Social deterioration} \quad (\text{II.B})$$

Cultural and Recreational Expenses

It is the same indicator employed for ET (Annex I), translated by the same conversion factors.

The “converted contribution” of Cultural and Recreational Expenses to the functioning SI is:

$$\text{Cultural and Recreational Expenses} * \text{Books} * \text{Family with PC} * \text{Non repeating students} / \text{Social deterioration} \quad (\text{II.C})$$

Annex III – Simulations for Education and Training

At initial time ($t = 0$) the functioning Education and Training has the values reported in the following table.

⁴¹ Internet: <http://demo.istat.it/>

Table III.1 – Education and Training

Values	Lombardy	Emilia R.	Campania
ET	1.114	1.508	0.291
ET vs. average	+ 11.43%	+ 50.84%	-70.86%

Legenda:

ET = absolute value of the functioning

ET% vs. average = percentage variance of the functioning from national average

We hereafter report the results of the two explicative simulations with steady positive and negative growth rates for all the commodities.

Simulation III.A

Steady positive growth rate of 2.4% per year (0.6% per quarter) for all the commodities.

Table III.2 – Lombardy

Time	ET	ET% vs. average	% increase ⁴²
0	1.114	11.43	n.a.
1	1.121	12.10	0.60
2	1.128	12.77	1.21
3	1.134	13.45	1.81
4 (year 1)	1.141	14.13	2.43
5	1.148	14.82	3.04
6	1.155	15.51	3.66
7	1.162	16.20	4.29
8 (year 2)	1.169	16.90	4.91
9	1.176	17.60	5.54
10	1.183	18.31	6.18
11	1.190	19.02	6.82
12 (year 3)	1.197	19.74	7.46

Legenda:

ET% vs. average = percentage variance of the functioning from national average

% increase = percentage increase of the functioning over the time horizon

⁴² The percentage increases and decreases of the simulations for Education and Training reported in the fourth columns of tables from III.2 to III.7 are the same only for rounding reasons: they in fact differ from the third decimal onward.

Table III.3 – Emilia Romagna

Time	ET	ET% vs. average	% increase
0	1.508	50.84	n.a.
1	1.517	51.74	0.60
2	1.527	52.66	1.21
3	1.536	53.57	1.81
4 (year 1)	1.545	54.50	2.43
5	1.554	55.43	3.04
6	1.564	56.36	3.66
7	1.573	57.30	4.29
8 (year 2)	1.582	58.25	4.91
9	1.592	59.20	5.54
10	1.602	60.16	6.18
11	1.611	61.12	6.82
12 (year 3)	1.621	62.09	7.46

Table III.4 – Campania

Time	ET	ET% vs. average	% increase
0	0.291	-70.86	n.a.
1	0.293	-70.69	0.60
2	0.295	-70.51	1.21
3	0.297	-70.33	1.81
4 (year 1)	0.298	-70.15	2.43
5	0.300	-69.97	3.04
6	0.302	-69.79	3.66
7	0.304	-69.61	4.29
8 (year 2)	0.306	-69.43	4.91
9	0.308	-69.25	5.54
10	0.309	-69.06	6.18
11	0.311	-68.88	6.82
12 (year 3)	0.313	-68.69	7.46

Simulation III.B

Steady negative growth rate of 2.4% per year (0.6% per quarter) for all the commodities.

Table III.5 – Lombardy

Time	ET	ET% vs. average	% decrease
0	1.114	11.43	n.a.
1	1.108	10.76	0.60
2	1.101	10.10	1.19
3	1.094	9.44	1.79
4 (year 1)	1.088	8.78	2.37
5	1.081	8.13	2.96
6	1.075	7.48	3.54
7	1.068	6.84	4.12
8 (year 2)	1.062	6.20	4.69
9	1.056	5.56	5.26
10	1.049	4.93	5.83
11	1.043	4.30	6.39
12 (year 3)	1.037	3.68	6.95

Legenda:

ET% vs. average = percentage variance of the functioning from national average

% decrease= percentage decrease of the functioning over the time horizon

Table III.6 – Emilia Romagna

Time	ET	ET% vs. average	% decrease
0	1.508	50.84	n.a.
1	1.499	49.93	0.60
2	1.490	49.04	1.19
3	1.481	48.14	1.79
4 (year 1)	1.473	47.26	2.37
5	1.464	46.38	2.96
6	1.455	45.50	3.54
7	1.446	44.63	4.12
8 (year 2)	1.438	43.76	4.69
9	1.429	42.90	5.26
10	1.420	42.05	5.83
11	1.412	41.20	6.39
12 (year 3)	1.404	40.35	6.95

Table III.7 – Campania

Time	ET	ET % vs. average	% decrease
0	0.291	-70.86	n.a.
1	0.290	-71.04	0.60
2	0.288	-71.21	1.19
3	0.286	-71.38	1.79
4 (year 1)	0.284	-71.55	2.37
5	0.283	-71.72	2.96
6	0.281	-71.89	3.54
7	0.279	-72.06	4.12
8 (year 2)	0.278	-72.23	4.69
9	0.276	-72.39	5.26
10	0.274	-72.56	5.83
11	0.273	-72.72	6.39
12 (year 3)	0.271	-72.89	6.95

Annex IV – Simulations for Social Interactions

At initial time ($t = 0$) the functioning Social Interactions has the values reported in the following table.

Table IV.1 – Education and Training

<i>Values</i>	Lombardy	Emilia R.	Campania
SI	0.772	1.519	0.279
SI vs. average	- 22.83%	+ 51.87%	-72.10%

Legenda:

SI = absolute value of the functioning

SI% vs. average = percentage variance of the functioning from national average

We hereafter report the results of the two explicative simulations above mentioned.

Simulation IV.C

Steady positive growth rate of 2.4% per year (0.6% per quarter) for all the commodities.

Table IV.2 – Lombardy

Time	SI	SI % vs. average	% increase
0	0.772	-22.83	n.a.
1	0.774	-22.62	0.28
2	0.776	-22.39	0.57
3	0.778	-22.17	0.86
4 (year 1)	0.781	-21.94	1.16
5	0.783	-21.71	1.46
6	0.785	-21.48	1.76
7	0.788	-21.24	2.07
8 (year 2)	0.790	-21.00	2.38
9	0.792	-20.76	2.69
10	0.795	-20.51	3.01
11	0.797	-20.27	3.33
12 (year 3)	0.800	-20.02	3.65

Legenda:

SI% vs. average = percentage variance of the functioning from national average

% increase = percentage increase of the functioning over the time horizon

Table IV.3 – Emilia Romagna

Time	SI	SI % vs. average	% increase
0	1.519	51.87	n.a.
1	1.522	52.20	0.22
2	1.525	52.53	0.44
3	1.529	52.87	0.66
4 (year 1)	1.532	53.21	0.89
5	1.536	53.56	1.12
6	1.539	53.92	1.35
7	1.543	54.28	1.59
8 (year 2)	1.546	54.65	1.83
9	1.550	55.02	2.08
10	1.554	55.40	2.33
11	1.558	55.78	2.58
12 (year 3)	1.562	56.17	2.84

Table IV.4 – Campania

Time	SI	SI % vs. average	% increase
0	0.279	-72.10	n.a.
1	0.280	-72.04	0.20
2	0.280	-71.99	0.40
3	0.281	-71.93	0.60
4 (year 1)	0.281	-71.87	0.81
5	0.282	-71.81	1.02
6	0.282	-71.75	1.24
7	0.283	-71.69	1.46
8 (year 2)	0.284	-71.63	1.68
9	0.284	-71.57	1.91
10	0.285	-71.50	2.14
11	0.286	-71.44	2.37
12 (year 3)	0.286	-71.37	2.61

Simulation IV.D

Steady negative growth rate of 2.4% per year (0.6% per quarter) for all the commodities.

Table IV.5 – Lombardy

Time	SI	SI % vs. average	% decrease
0	0.772	-22.83	n.a.
1	0.769	-23.05	0.28
2	0.767	-23.27	0.56
3	0.765	-23.48	0.83
4 (year 1)	0.763	-23.69	1.10
5	0.761	-23.89	1.37
6	0.759	-24.10	1.64
7	0.757	-24.30	1.90
8 (year 2)	0.755	-24.50	2.15
9	0.753	-24.69	2.41
10	0.751	-24.88	2.66
11	0.749	-25.07	2.90
12 (year 3)	0.747	-25.26	3.14

Legenda:

SI% vs. average = percentage variance of the functioning from national average

% decrease = percentage decrease of the functioning over the time horizon

Table IV.6 – Emilia Romagna

Time	SI	SI % vs. average	% decrease
0	1.519	51.87	n.a.
1	1.515	51.54	0.21
2	1.512	51.22	0.42
3	1.509	50.91	0.63
4 (year 1)	1.506	50.60	0.83
5	1.503	50.30	1.03
6	1.500	50.00	1.23
7	1.497	49.71	1.42
8 (year 2)	1.494	49.42	1.61
9	1.491	49.14	1.79
10	1.489	48.87	1.98
11	1.486	48.60	2.15
12 (year 3)	1.483	48.33	2.33

Table IV.7 – Campania

Time	SI	SI % vs. average	% decrease
0	0.279	-72.10	n.a.
1	0.278	-72.15	0.19
2	0.278	-72.21	0.39
3	0.277	-72.26	0.57
4 (year 1)	0.277	-72.31	0.76
5	0.276	-72.36	0.94
6	0.276	-72.41	1.12
7	0.275	-72.46	1.29
8 (year 2)	0.275	-72.51	1.46
9	0.274	-72.55	1.62
10	0.274	-72.60	1.79
11	0.274	-72.64	1.95
12 (year 3)	0.273	-72.69	2.10

Bibliography

- Balestrino, A., Sciclone, N., 2001, Should we measure functionings instead of income to measure well-being? Theory, and some evidence from Italy, *Rivista Internazionale di Scienze Sociali*, Anno CIX, n.1
- Brandolini, A., D'Alessio, G., 1998, Measuring well-being in the functioning space. Roma: *Mimeo Banca d'Italia*
- Chiappero Martinetti, E., 1994, A new approach of well-being and poverty by fuzzy set theory, *Giornale degli Economisti e Annali di Economia*, vol. LIII (N.S.) - n. 7-9 pp. 367-388
- Chiappero Martinetti, E., 1996, Standard of living evaluation based on Sen's approach: some methodological suggestions, *Notizie di Politeia*, 12, 43/44, pp. 37-53
- Chiappero Martinetti, E., 2000, A multidimensional assessment of well-being based on Sen's functioning approach, *Rivista Internazionale di Scienze Sociali*, n. 2, 2000
- Dasgupta, P., 1993, *An inquiry into well-being and destitution*. Oxford: Clarendon Press
- Dasgupta, P., 1999, Valuation and evaluation: measuring the quality of life and evaluating policy. London, *The Suntory Centre, London School of Economics and Political Sciences*
- Detsch, J., Silber, J., Yacouel, N., 2001, On the measurement of inequality in the quality of life in Israael, *Paper presented at the conference on "Justice and Poverty: examining Sen's Capability Approach"*. Cambridge: *The Von Hügel Institute, St. Edmund's College, University of Cambridge, June 2001*
- Granaglia, Elena, 1994, Più o meno eguaglianza di risorse? Un falso problema per le politiche sociali, *Giornale degli Economisti e Annali di Economia*, vol. LIII (N.S.) - n. 7-9 pp. 349-366
- Grasso, M., 2002, Una misurazione del benessere nelle regioni italiane, *Politica Economica*, a. XVIII, n. 2, pp. 261-292
- Harrison, M., 2001, From theory to measurement: some issues raised in operationalising Professor Sen's capability approach, *Paper presented at the conference on "Justice and Poverty: examining Sen's Capability Approach"*. Cambridge: *The Von Hügel Institute, St. Edmund's College, University of Cambridge, June 2001*
- Klasen, S., 2000, Measuring poverty and deprivation in South Africa, *Review of Income and Wealth*, Series 46, Number 1, pp. 33-58
- Krzyzanowski, M., 2001, *What are the implications of what we do and do not know for health impact assessment?*, WHO: Bruxelles/Geneve
- Laudisa, F., 2000, Valutare gli effetti occupazionali della formazione utilizzando i non ammessi ai corsi come gruppi di controllo, *Relazione preparata per il III Congresso dell'Associazione Italiana di Valutazione*, 23-25 marzo 2000
- Marselli, R., Vannini, R., 2000, Quanto incide la disoccupazione sui tassi di criminalità? *Rivista di Politica Economica*, Ottobre 2000, pp. 273-299
- MIT System Dynamics Group, 1996-2000, *Road maps: a guide to learning system dynamics*, Boston, MIT. Internet:<http://sysdyn.mit.edu/road-maps/home.html>
- Nussbaum, M., 2000, *Women and human development. The capability approach*. Cambridge: Cambridge University Press
- ODI, 2001, *Economic theory, freedom and human rights: the work of Amartya Sen*, London: ODI Briefing Paper November 2001
- Olson M., 1969, *Toward a Social Report*. Washington, D.C: U.S. Department of Health, Education, and Welfare
- Rawls, J., 1971, *A Theory of Justice*, Cambridge: Harvard University Press
- Robeyns, I., 2000, An unworkable idea or a promising alternative? Sen's capability approach re-examined, *Mimeo, University of Cambridge, Wolfson College*

- Ruth, M., Hannon, B., 1997, *Modeling dynamic economic systems*, New York: Springer-Verlag
- Saith, R., 2001, Capabilities: the concepts and its operationalization, *University of Oxford, QEH Working Paper Series – QEHWPS66*
- Sen, A., K., Anand S., 1994, *Human Development Index: Methodology and Measurement*. New York: Human Development Report Office, Occasional Paper n. 12
- Sen, A., K., 1979, Utilitarianism and welfarism, *The Journal of Philosophy*, Vol. 76 NO. 9, pp. 463-489
- Sen, A., K., 1980, Equality of what?, in Mc Murrin S. (ed.), *The Tanner Lectures on Human Values*, Cambridge: Cambridge University Press, reprinted in Sen (1982) ch. 16
- Sen, A., K., 1982, *Choice, welfare and measurement*. Oxford: Basic Blackwell,
- Sen, A., K., 1985, *Commodities and Capabilities*. Amsterdam: North-Holland.
- Sen, A., K., 1987(a), *On ethics and economics*. Oxford: Basic Blackwell
- Sen, A., K., 1987(b), *The standard of living*. Cambridge: Cambridge University Press
- Sen, A., K., 1991, Welfare preference and freedom, *The Journal of Econometrics*, Vol. 50, pp. 15-29
- Sen, A., K., 1992, *Inequality reexamined*. Cambridge: Harvard University Press
- Sen, A., K., 1993, *Capability and Well-being*, in *The Quality of Life* (edited by Nussbaum, M. and Sen, A., K.), pp. 31-53. Oxford: Clarendon Press
- Sen, A., K., 1994, Well-being, capability and public policy, *Giornale degli Economisti e Annali di Economia*, vol. LIII (N.S.) - N. 7-9 pp. 333-347
- Sen, A., K., 1995, Rationality and social choice, *The American Economic Review*, Vol. 85 NO. 1, pp. 1-24.
- Sen, A., K., 1996, Freedom, capabilities and public action, *Notizie di Politeia*, 12, 43/44, pp. 107-125.
- Sen, A., K., 1997, Inequality, unemployment and contemporary Europe, *International Labour Review*, Vol. 136, NO. 2 pp. 155-171
- Sen, A., K., 1999, *Development as freedom*. New York: Anchor Books
- Sen, A., K., 1999, The possibility of social choice, *The American Economic Review*, Vol. 89 NO. 3, pp. 1-24